

OWNER'S MANUAL

THE GRAND FINALE

24" and 36" Finish Applicator

**Now with Spray Handle Upgrade*



WWW.AZTECPRODUCTS.COM

215-393-4700 TOLL FREE: 800-331-1423 FAX: 215-393-4800
201 COMMERCE DRIVE, MONTGOMERYVILLE, PA 18936



TABLE OF CONTENTS

INTRODUCTION	PG 3
GENERAL SAFETY MESSAGE INFORMATION	PG 3-4
GRAND FINALE DIAGRAM	PG 5
RECEIVING YOUR NEW GRAND FINALE	PG 5
GRAND FINALE ASSEMBLY	PG 6
OPERATING THE GRAND FINALE	PG 7
FLOW SETTINGS	PG 7
BATTERY CHARGING	PG 8
GROUNDING INSTRUCTIONS	PG 9
CLEANING AND STORAGE	PG 10
GRAND FINALE PARTS AND DIAGRAMS:	
<i>BODY PARTS AND DIAGRAM</i>	PG 11-12
<i>ASSEMBLY PARTS AND DIAGRAM</i>	PG 13
TROUBLESHOOTING	PG 14
RETURN GOODS POLICY	PG 15
GRAND FINALE WARRANTY	PG 16
RETAILER / DISTRIBUTOR CONTACT INFO	PG 16

INTRODUCTION

Thank you for purchasing this Aztec Products, Inc. machine. You have purchased a quality product and we welcome you to the Aztec family. It is critically important to utilize proper training, understanding, maintenance and care for this product. Neglect of the Safety Messages, especially the **DANGER**, **WARNING**, **CAUTION** and **NOTICE** statements throughout this Owner's Manual may lead to serious injury or death, and/or cause damage to the floor and/or facility.

For best results from your Aztec machine, you must read and understand this Owner's Manual, and follow all operation guidelines and safety messages. Protect your **WARRANTY** by following all maintenance guidelines and keeping a dated log. If a problem should arise, consult an authorized Aztec service center.

All information in this Owner's Manual is up to date and based on the latest product information available at the time of printing. Aztec Products, Inc. reserves the right to make changes at any time without notice or incurring obligation. This Owner's Manual and the maintenance log must be kept as a permanent part of the machine and remain with the machine if resold.

No part of this document may be copied or reproduced without written permission.

GENERAL SAFETY MESSAGE INFORMATION

Your safety and the safety of others is very important. As the manufacturer, we have provided important safety messages throughout this manual and on the machine. The purpose of these safety messages is to prevent damage to you, your machine, the property, and/or the environment.

Please read and understand this information thoroughly. A safety message alerts you to potential hazards that could result in injury or death, and/or cause damage to the floor and/or facility. Each safety message is preceded by a universal safety alert symbol (!) and one of these safety words: **DANGER**, **WARNING**, **CAUTION**, or **NOTICE**. These signal words mean:

	DANGER indicates a hazardous situation which, if not avoided, will result in death or serious injury
	WARNING indicates a hazardous situation which, if not avoided, could result in death or serious injury.
	CAUTION indicates a hazardous situation which, if not avoided, could result in minor or moderate injury
	NOTICE is used to address practices not related to physical injury

IMPORTANT SAFETY INFORMATION

The Grand Finale coatings applicator is designed to apply an even coat of VCT floor finish, concrete densifier, hardener, sealer, and water or solvent based concrete coating. The Grand Finale is not recommended for any other use. Call Aztec 800-331-1423 for additional application questions.

Aztec's Grand Finale is a simple, rugged, American-made floor coatings application machine designed to apply floor finish, concrete densifiers, hardeners and sealers quickly and uniformly.

*The Grand Finale, available in both 24" or 36" pad width, provides an easy, high-speed way to lay down a smooth, uniform coat of chemicals at up to **35,000 sqft/hr** (3252 square meters/hour). At **8X** faster than the traditional mop and bucket method, the Grand Finale eliminates baseboard splash and puddling, all while reducing chemical usage by 30% and eliminating strenuous labor and injury.*

A battery-powered pump precisely controls the flow rate to a microfiber or looped pad. Using a magnetic sensor and pressure controlled pump, the chemicals flow from the bucket through the machine and onto the floor, providing NO streaking or edge bleeding.

*The Grand Finale is the "Step Four" of the **Aztec WorkSmart™ Sidewinder Stripping System**, which includes the **Liquidator** (strip solution applicator), the **Sidewinder** (propane floor stripper), and the **Guzzler** (slurry retriever).*

All of Aztec's machines proudly MADE IN THE USA.

NOTE: Aztec's SPRAY GRAND FINALE upgrade features a spray nozzle and flexible hose to access smaller areas.

WARNING

Use water-based liquids only. Do not use acetone, aromatic or aliphatic solvents; no petroleum based coatings, solvents or epoxy.

CAUTION

Do not attempt to ride on or otherwise attach any type of rider platform to this machine. Injury and property damage may occur.

CAUTION

Safety is a full-time, every day job. Never let an untrained or irresponsible person operate the machine. They may hurt themselves and/or damage the floor or other property.

NOTICE

Make sure the operator receives adequate instruction before operating the equipment.

NOTICE

When applying chemical to large areas, the chemical may dry before the next pass is made. Finish smaller sections at a time so you can always keep a wet edge to overlay.

NOTICE

Only for use with coatings and floor finish up to 40% solid. Clean after each use.

NOTICE

Always pre-sweep or dust mop floor. Debris in pad can cause streaks.

GRAND FINALE DIAGRAM

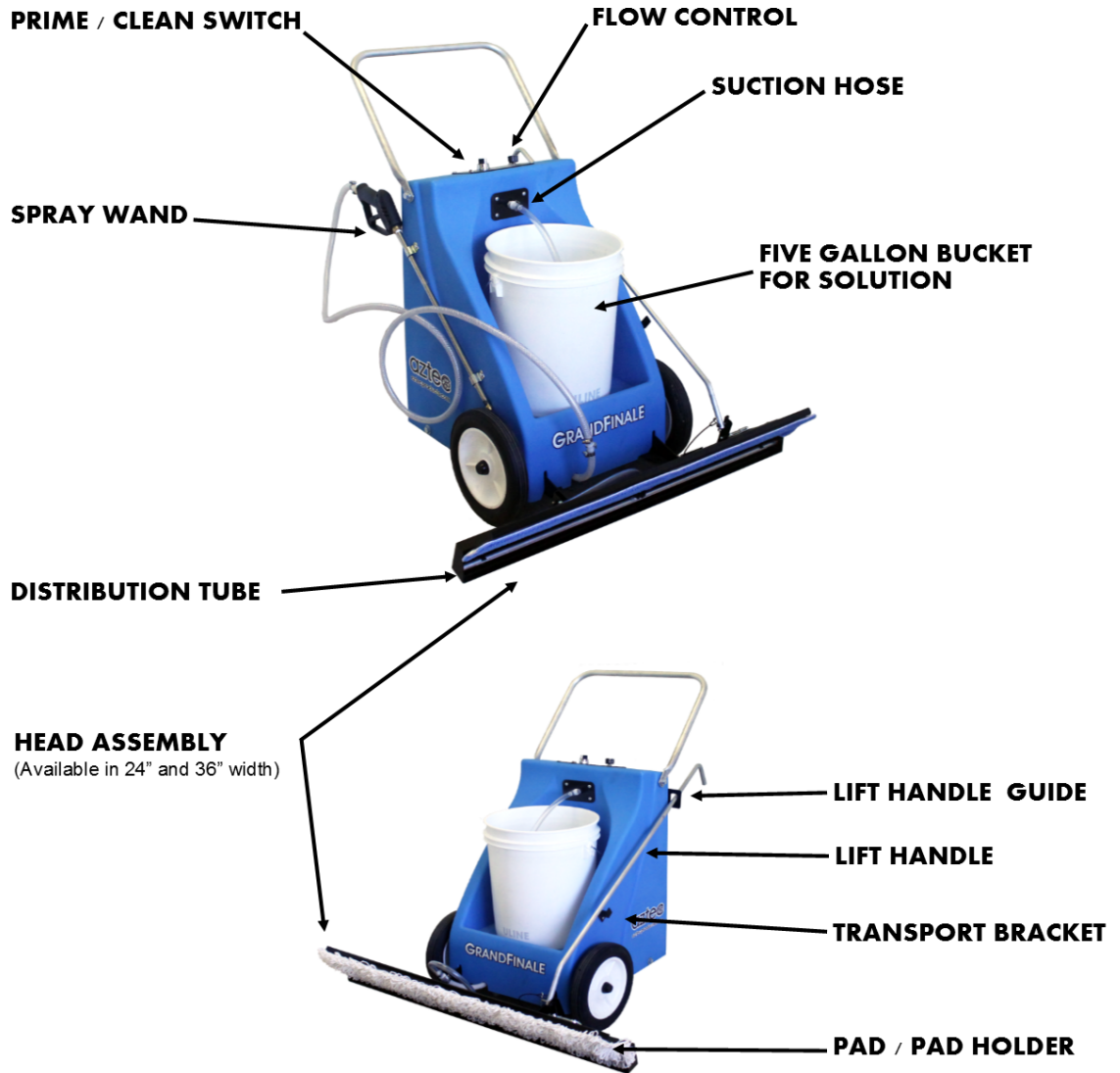

NOTICE

Only for use with coatings and floor finish up to 40% solid. Clean after each use.



WARNING

Use water-based liquids only. Do not use acetone, aromatic or aliphatic solvents; no petroleum based coatings, solvents or epoxy.

RECEIVING YOUR NEW GRAND FINALE

You should receive two packages: one large and one small. The large shipping carton should contain the following items:

- 1 Applicator Base Unit
- 1 Lift Handle Assembly
- 1 Empty Pail
- 1 Suction Hose Assembly
- 1 Battery Pack
- 1 Small Parts Package (lift handle, lift pins, distribution tube end caps and paper clips)
- 1 Power Cord

The small shipping carton should contain the following parts:

- 1 Cleaning Tray
- 1 Head Assembly
- 1 Applicator Pad
- 1 Head Cover

GRAND FINALE ASSEMBLY

- 1.) Attach the *Head Assembly* and the *Pad Holder* to the front of the Grand Finale.
- 2.) Insert the *Lift Handle* through the *Lift Handle Guide* and over the *Transport Bracket*, then attach the *Lift Handle* to the *Head Assembly*. Secure the *Lift Handle* to the *Head Assembly* with pin.
- 3.) Connect *Feed Hose* to *Head Assembly* and *Suction Hose* to front panel.
- 4.) Make sure battery is fully charged. If not, connect the power cord to the receptacle on the back of the body. Connect to a power source and charge battery until "Charged" light is lit. Remove power cord when battery is fully charged.
- 5.) Pour about one quart of finish or coating solution into the Grand Finale bucket and saturate *Pad* in solution.
- 6.) Wring out *Pad* and lay flat on floor, back side up.
- 7.) Place solution or finish container on Grand Finale and insert the *Suction Hose* into container.
- 8.) Pull back on *Lift Handle* to raise *Head Assembly* and *Pad Holder*. Lower *Pad Holder* onto saturated *Pad*.
- 9.) Turn control switch to PRIME/CLEAN and hold in that position until finish/solution sprays from Head Assembly. Release to return switch to OFF position, then move switch to RUN.
- 10.) Turn *Flow Control* to desired setting. Higher viscosity fluids will require a numerically higher setting.
- 11.) Pull Grand Finale backwards about 20 feet and check coverage.
- 12.) Adjust *Flow Control* to get coverage desired.

OPERATING THE GRAND FINALE

CAUTION

Always check the long, metal Distribution Tube to make sure all holes are clean. Clogged holes will prevent an even, smooth coating of solution.

- ❖ Review **GENERAL SAFETY MESSAGE INFORMATION** on pg 4-5.
- ❖ Turn the control switch to RUN when starting normal operation.
- ❖ Pull the Grand Finale behind you as you walk so as not to walk on top of freshly laid solution.
- ❖ Walk at a comfortable speed. Do not walk faster than the applicator can evenly spread the finish.
- ❖ Turn flow control switch to zero before making the turn at end of each pass to prevent over saturation of pad. Turn control switch back to desired flow setting after making each turn.
- ❖ Turn flow control switch to zero, 10 feet before finishing an area to minimize dripping.
- ❖ If floors are thoroughly stripped or have not been coated before, walk slow and increase flow for the first coat. This will eliminate streaking.
- ❖ Not all finishes/chemicals are the same. It may be necessary to try different settings or walking speeds for optimal results.
- ❖ Ensure battery is fully charged prior to starting the job (see pg 8).

Taking corners:

- Push Grand Finale straight forward toward corner after making turn
- Pull straight back until pad is past wet edge
- Swing Grand Finale outside wet edge and push forward
- Continue parallel to previous pass, overlapping by 4"
- Continue process until entire floor is covered, leaving an exit path.
- Shut off solution supply 10 feet before finish to minimize dripping.

FLOW SETTINGS FOR 24" GRAND FINALE

Surface Type	Flow Setting
Floor Finish/Sealer on VCT	1 – 2
Concrete/Gym Coating	2.5 – 7

FLOW SETTINGS FOR 36" GRAND FINALE

Surface Type	Flow Setting
Floor Finish/Sealer on VCT	1.5 – 2.5
Concrete/Gym Coating	3 – 8

BATTERY CHARGING

CAUTION

This product must be grounded while charging to protect the operator from electric shock. The power cord plug **MUST** be plugged into a matching electrical receptacle that is properly grounded in accordance with ALL local codes and ordinances.

CAUTION

Before any battery maintenance is done, make sure batteries and charger are disconnected and unplugged from wall outlet to avoid shock.

CAUTION

Disconnect power before using the machine. Electric shock may occur.

NOTICE

Keep battery terminals and surface area clean and dry.

NOTICE

Safety first. Contact an authorized service center as needed.

- 1.) Before charging the battery, read through the **GROUNDING INSTRUCTIONS** on pg 9.
- 2.) Charge battery by connecting the power cord to the power inlet on the back side of the Grand Finale. Connect the power cord into a 120v grounded outlet. The GREEN light will come on when the power is connected. Allow battery to charge until "charged" and the RED indicator light glows. Disconnect power cord when fully charged.
- 3.) Battery Low indicator light on control panel will glow when approximately 10 minutes run time remain. Battery run time is 5-7 hours.

GROUNDING INSTRUCTIONS

⚠ DANGER

Do not modify the power plug provided. Use only a 3-wire extension cord that has a 3-prong grounding plug and a 3-pole receptacle that accepts the power supply cord's plug. Replace a damaged or worn cord immediately.

⚠ WARNING

The Grand Finale must be grounded while in use to protect the operator from electrical shock. It is equipped with a power cord that has a grounding conductor and a grounding plug. The plug **MUST** be plugged into a matching electrical receptacle that is properly installed and grounded in accordance with local codes and ordinances.

Improper electrical connection of the equipment-grounding conductor can result in risk of electrical shock. The conductor with green insulation (with or without yellow stripes) is the equipment grounding conductor.

Check with a qualified electrician or service personnel if you do not completely understand the grounding instructions, or if you are not sure the equipment is properly grounded.

This product is intended for use on a circuit that has an electrical receptacle with a grounding conductor as shown in Figure 1.

If a properly grounded electrical receptacle is not available, an adapter (see Figure 2) can be used to temporarily connect this plug to a 2-contact ungrounded receptacle. The adapter has a rigid lug extending from it that **MUST** be connected to a permanent earth ground, such as a properly grounded receptacle box. **THIS ADAPTER IS PROHIBITED IN CANADA.**

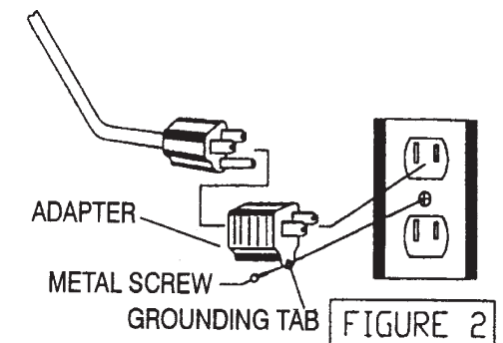
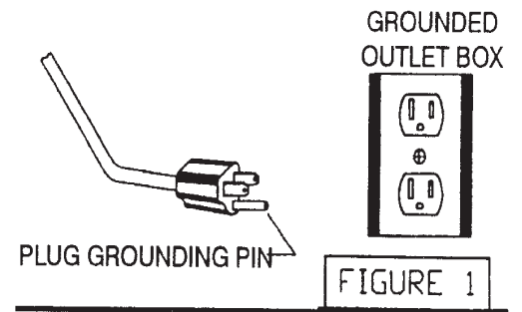

CLEANING AND STORAGE

CAUTION

Failure to clean the Grand Finale as directed will void the Warranty.

CAUTION

If solvent based coatings are used, the Grand Finale must be flushed with mineral spirits before beginning to clean up and store.

NOTICE

If taking a break from the job, the head cover bag may be placed over head and pad holder to keep solution on surfaces from drying.

NOTICE

Please responsibly dispose of dirty water and used chemicals.

- 1.) After completing final pass, retract *Head Assembly* and lock *Lift Handle* in lifted, transport position.
- 2.) Remove pad and completely rinse with clean water or store in a sealed plastic bag.
- 3.) Remove *Suction Hose* from wax/coating container and remove container. Cap the unused wax/coating; store in a safe, secure place. Place the Grand Finale cleaning bucket filled with two quarts of water on the Grand Finale.
- 4.) Install cleaning bucket with clean water and insert *Suction Hose* in bucket.
- 5.) Retract *Head Assembly* to cleaning position and secure *Lift Handle* in place.
- 6.) Place cleaning tray in front of Grand Finale and position *Head Assembly* over the cleaning tray.
- 7.) Turn *Control Knob* to PRIME/CLEAN and completely flush system with clean water.
- 8.) Disconnect *Suction Hose* and turn *Control Switch* to PRIME/CLEAN to purge remaining water from Grand Finale.
- 9.) Open a paper clip and use tip to clear solution from groove in *Distribution Tube*.
- 10.) Push end of paper clip through any plugged holes to clear holes.
- 11.) After cleaning *Distribution Tube*, dump water from cleaning tray.
- 12.) Disconnect *Lift Handle* from the head, store handle in the transport notch position and resting in the *Transport Bracket*.
- 13.) Disconnect *Suction Hose* and remove *Head Assembly*; rinse off and store with pad in head cover.

GRAND FINALE BODY PARTS DIAGRAM

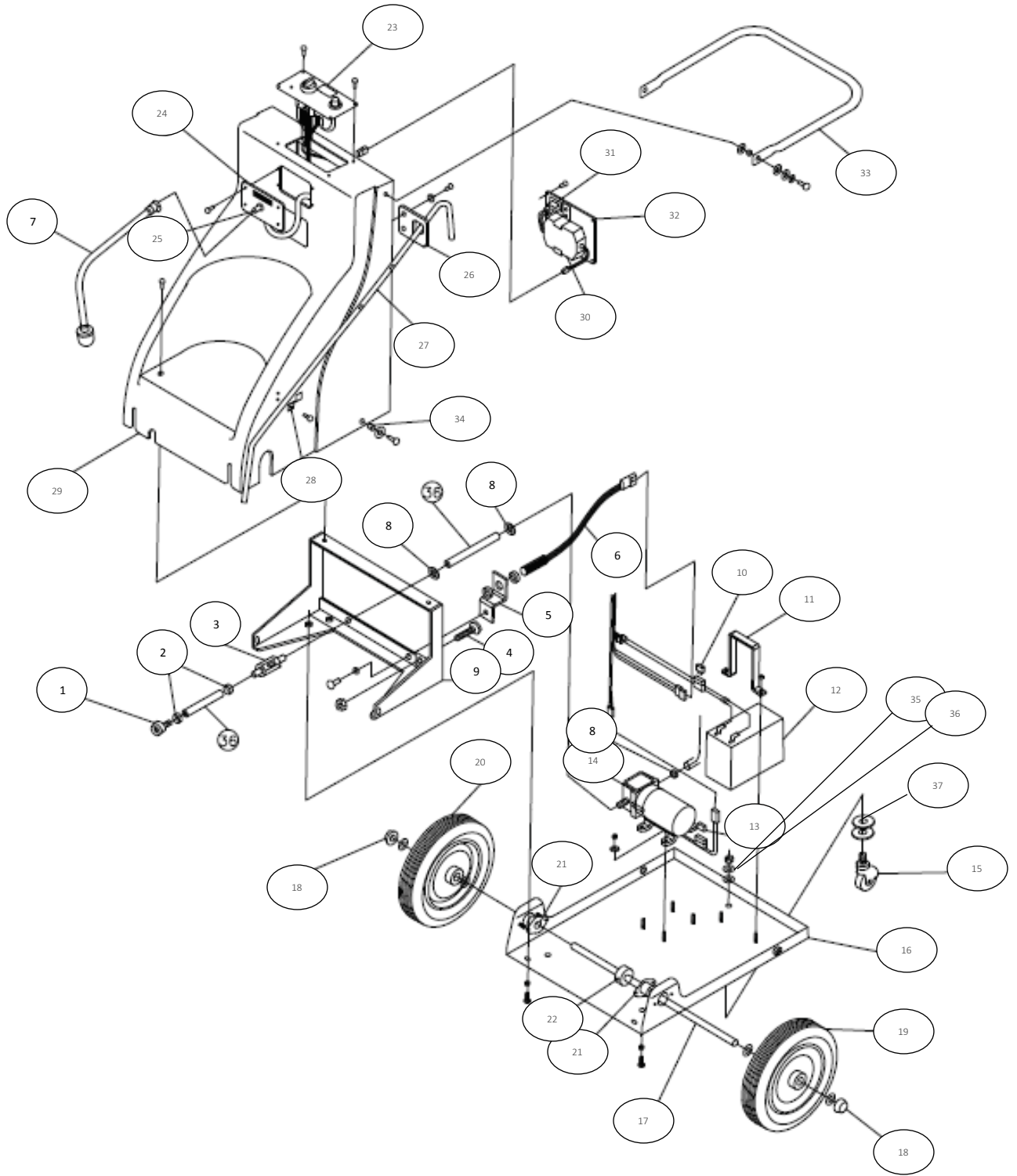

GRAND FINALE BODY PARTS LIST

REF #	DESCRIPTION	PART #	QTY
1	Quick Coupling Body	050-270	1
2	Hose Clamp (Steel)	050-320	2
3	Check Valve	050-120	1
4	Axle Bumper	050-230	1
5	Axle Sensor Bracket	370-050-185	1
6	Axle Sensor	050-140	1
7	Suction Tube Assembly	050-151	1
8	Hose Clamp (Nylon)	050-310	3
9	Pad Holder Support Assembly	370-050-170	1
10	Fuse 3 Amp (Battery)	050-3AMP	1
11	Battery Hold Down Bracket	370-050-160	1
12	Battery (12 Volt)	050-170	1
13	Fuse 5 Amp (Pump)	050-5AMP	1
14	Pump	050-390	1
15	2" Swivel Caster	050-330	1
16	Steel Body Frame Assembly	370-050-190	1
17	Axle	218-.5-304 SS BAR	1
18	Axle Cap Nut	050-220	2
19	10x1.75 Wheel w/Bushing	156-050-1	1
20	10x1.75 Wheel w/Bearing	156-050-2	1
21	Axle Flange Bearing	050-160	2
22	Magnet Mount Bushing Assembly	050-420	1
23	Wire Harness Assembly	153-050	1
24	Suction Tube Plate	370-050-150	1
25	Quick Coupling Insert	050-290	1
26	Lift Handle Adjustment Bracket	370-050-140	1
27	Lift Handle	283-050-135	1
28	Lift Handle Support Bracket	283-050-145	1
29	Body (Plastic)	108-050	1
30	Battery Charger 12V 1.5 Amp	050-130	1
31	Power Receptacle	050-400	1
32	Battery Charger Mount Plate Assembly	370-050-155	1
33	Handle	283-050-195	1
34	Body Spacer	050-190	2
35	Lock washer	164-20156	1
36	Nut	164-22002	1
37	Washer	164-20157	3

GRAND FINALE ASSEMBLY PARTS LIST

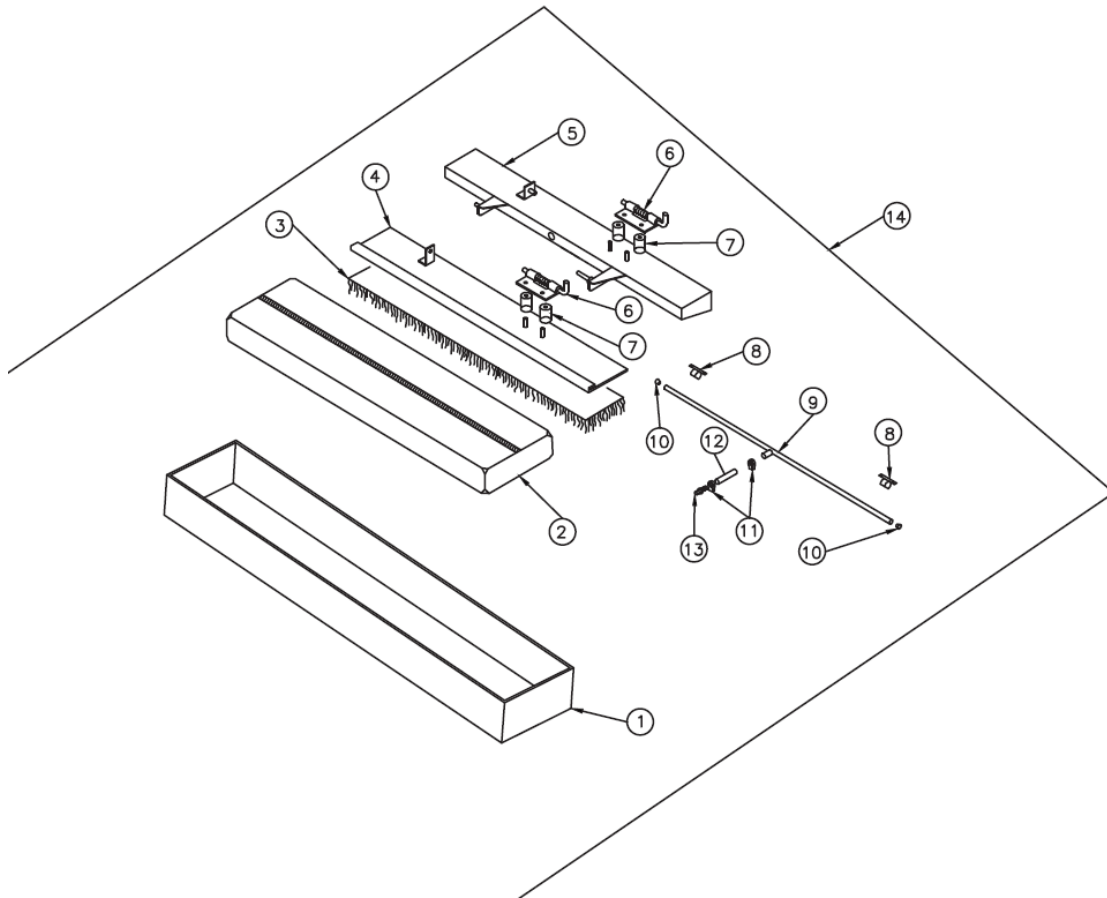

REF #	DESCRIPTION	PART #	QTY
1	24" Drip Tray 36" Drip Tray	370-050-210-24 370-050-210	1 1
2	24" Head Cover Bag (Velcro® Closure) 36" Head Cover Bag (Velcro® Closure)	050-440-24 050-440	1 1
3	24" Thin Microfiber Pad 24" Looped Microfiber Pad 36" Thin Microfiber Pad 36" Looped Microfiber Pad	050-24-C 050-24-F 050-36-C 050-36-F	1 1 1 1
4	24" Pad Holder Assembly 36" Pad Holder Assembly	370-050-100-24 370-050-100	1 1
5	24" Manifold Housing Assembly 36" Manifold Housing Assembly	370-050-115-24 370-050-115	1 1
6	Spring Latch Pin	625-32854440	2
7	Applicator Spacer	050-200	4
8	Manifold Mounting Clip	050-350	2
9	24" Manifold 36" Manifold	283-050-130-24 283-050-130	1 1
10	Manifold Tube Caps	050-100	2
11	Hose Clamp (Nylon)	050-310	2
12	3/8 x 9/16 Clear Tubing	216-0609	1
13	Quick Coupling Insert	050-280	1
14	24" Head Assembly (Complete) 36" Head Assembly (Complete)	050-H-24 050-H-36	1 1

TROUBLESHOOTING

PROBLEM	SYMPTOM	SOLUTION
Machine leaves streaks	Pad has excessive debris	Put pad holder in UP position and remove debris from pad.
	Suction line filter blocked or restricted	Remove suction line and rinse with hot water.
	Distribution tube is blocked	Remove trough assembly from machine. Remove distribution tube from trough and clean tube using clean-out brush or paper clip.
	Floor re-coated too soon	Allow adequate drying time between coats. Burnish after 24 hours.
Pump will not run	Switch is off	Put switch in the ON position.
	Battery is discharged	Test by switching to the prime position. If the pump fails to run the battery needs to be charged.
	Hall Effect switch	<p>If the pump runs in the PRIME position but not when being pulled, the magnet that trips the axle position sensor switch may be out of alignment. Open the body and visually check the nylon hub (item 22 on the axle. It should be centered in front of the hall effect switch (item 6). If not, first check for side play in the axle assembly. There should only be about 1/32" to 1/16" movement. Adjust if necessary by tapping the hubs on to the axle.</p> <p>If there isn't side play then loosen the setscrew in the nylon hub and move so that it is centered in front of the hall effect switch. Also check that the magnet has not come dislodged from the hub.</p> <p>Check the distance between the hub and the switch. This should be no more than 1/16".</p> <p>If this doesn't solve the problem and all electrical plugs are in place then a faulty hall effect switch may be the problem.</p>
Pump runs when unit is pulled in both directions	Drag on axle needs to be increased	Open the body and loosen the hex nut on bumper (item 4). Turn the bumper to increase the pressure on the axle so that when the left hand wheel turns in the forward motion, the axle does not turn but does turn in the rearward direction. Retighten the locking hex nut and close the body. (Left side is the side with the lift rod.)

RETURN GOODS POLICY

As our customer, you are aware that the design and construction of this product are both innovative and unique. In order to troubleshoot our equipment, we rely heavily on returned defective or failed parts so that we can examine the causes of failure. While this may at first seem to be an inconvenience, ultimately you benefit from safer, better designed machine components. Please give us the opportunity to serve you better by following these RGA (Return Goods Authorization) rules.

- 1) We maintain the serial number, date of shipment or sale, and customer name on each piece of equipment sold. If you were the purchaser, please reference that information on your request for replacement or repair. If you purchased the equipment through a dealer, please include the company name, the date, and the serial number of the product.
- 2) Ask for an RGA number when you are ordering the replacement part. Return the failed part within 14 days, freight prepaid, exactly as it was at the time of failure. Our inspection and evaluation will attempt to determine the probable cause of failure.
- 3) If our inspection reveals that the failed part was defective, we will credit your account for the entire amount of the part including your cost of return freight, but not packaging expense. When incomplete parts are returned for credit, their condition or state of incompleteness will be assessed against the credit claim.
- 4) We will not accept freight collect returns or returns that do not indicate the RGA # on the packing list.

Your satisfaction is extremely important to us. We intend to be reasonable on any matter that is related to our warranty service or other wear-related problems which our customers feel need attention. Please help us to help you. Before assuming that a part is defective, check the repair manual to see if the problem might be something that you or one of your employees might be capable of correcting. If it is not, follow the above policy and depend on us to respond quickly and responsibly.

PROTECT YOUR WARRANTY!

Read this Owner's Manual carefully; all questions regarding the care and safety of this equipment, please contact AZTEC PRODUCTS:

www.aztecproducts.com * info@aztecproducts.com * 800-331-1423

AZTEC GRAND FINALE LIMITED ONE YEAR WARRANTY

Aztec Products, Inc. warrants its products to be free from defects in material and workmanship for a period of one year from the date of sale.

Aztec Products, Inc. agrees, at its option, to repair or replace at its own expense any product or part(s) which examination proves to be defective in workmanship or materials provided that the purchaser notifies Aztec Products, Inc. directly, within the warranty period, and follows the Return Policy.

This warranty does not apply to or cover equipment damaged by misuse, abuse, neglect, accident, or any use not specified in the instruction manual, or any other circumstances that are out of the control of Aztec Products, Inc. or their authorized agents.

All repairs or changes must be made under the supervision or arrangement of Aztec Products, Inc. or their agents unless prior written consent has been issued. Any deviation from this arrangement shall make the owner of the equipment and/or party involved in those changes responsible for any and all damages resulting from such changes.

The foregoing is the entire and only Aztec Products, Inc. warranty which in no event covers incidental or consequential damages resulting from any such defective product or part(s). This warranty gives specific legal rights. Purchaser may have other rights which vary from state to state.

This warranty is non-transferable.
AZTEC PRODUCTS, INC. • www.aztecproducts.com
201 Commerce Drive • Montgomeryville, PA 18936 • 800-331-1423 • Fax 215-393-4800

RETAILER/DISTRIBUTOR CONTACT INFO

PURCHASE DATE:

DISTRIBUTOR NAME:

DISTRIBUTOR PHONE NUMBER(S):

NOTES: