

OWNER'S MANUAL

ULTRAEDGE Propane Concrete Edger



***Powered by the
EPA/Carb certified
Kawasaki
603cc Engine***

 **Green Cleaning**
Meets U.S. Green Building
Council LEED IEQ Credit
3.4 Requirements

MADE IN USA

IMPORTANT SAFETY INSTRUCTIONS

READ and UNDERSTAND all instructions and warnings before operating this machine!



WARNING

Do not store or use gasoline or other flammable vapors and liquids in the vicinity of this machine. Always store equipment away from heater rooms, boilers, gas-fired water heaters or any other source of open flame. Propane is highly flammable. Always store LPG tanks (full or empty) outside in a secure, well ventilated area.

NO SMOKING, NO SPARKS, NO FLAMES NEAR UNIT OR LPG TANK.

Operate only in well ventilated areas. Buildings must be provided with:

- A. A continuous mechanical ventilation that removes the products of combustion to the outdoors of not less than 300 CFM for each 10,000 BTUH or fraction thereof; or
- B. Natural ventilation of not less than 300 CFM for each 10,000 BTUH input or fraction thereof, based on a maximum of one-quarter air exchange per hour for the net building volume.

If you smell LPG gas, stop the unit and check for leaks. Also open windows, don't touch electrical switches, and extinguish any open flames. Call your gas supplier if no leaks are found.

Do not adjust the fuel system without the proper analysis equipment.



WARNING

Never tilt the equipment on its side for pad, belt or brush replacement. It is designed to tilt back on its rear wheels and body frame for maintenance and repair. A second person should aid in lifting and securing equipment for repair.

Never tilt & transport while engine is running.

Keep hands and feet clear of all moving parts.

Never try to replace parts or repair equipment with machine running.

Turn the gas off at the tank to kill the engine.

Remove the LPG tank and store it in an approved area when not in use. A "NO SMOKING" sign should be permanently displayed at the storage area.

Always vent an over-full bottle using the tank's bleed valve, out of doors away from all closed

places and away from any fire or flame producing device.

Keep all objects clear of the exhaust system during and after operation.

Do not leave this machine unattended while the engine is running.

Do not operate equipment in one location for more than a few seconds. Damage to floor surface can occur.

Always store equipment away from possible damage by falling objects in warehouse-type areas. Always store LPG tanks outside in a secure, well-ventilated area.

When the LPG tank is attached to the machine and not running, the operator should not leave the machine unattended except for short periods of time such as rest stops, washroom or meal stops.

The operator must completely understand all instructions, warnings and operating procedures before using this machine.

This machine must be maintained in accordance with this manual's recommended maintenance instructions and the engine manufacturer's recommended maintenance procedures. Failure to do so may cause damage to the machine, equipment, furniture, buildings or personal injury.

A maintenance record should be kept indicating date of service, hours on engine, and work done.



WARNING

Before attempting any maintenance procedures, close the service valve on the fuel cylinder and stop the engine.

If you smell propane odor, stop the engine, remove the cylinder and take it outside for inspection.

Exhaust parts are extremely HOT. Do NOT allow them to come into contact with anything or anyone.

Do not attempt to change diamonds while the engine is running.

Do not stand on machine.



WARNING

Follow the instructions given in this booklet, the Engine's Owners Manual and the training given by your supervisor for the safe operation of this machine. Failure to do so can result in personal injury and/or damage to the machine or property.

DO NOT OPERATE THIS MACHINE IN AN EXPLOSIVE ENVIRONMENT!

THIS PROPANE MACHINE IS INTENDED FOR COMMERCIAL USE.

TRANSPORTING THE MACHINE

NEVER TRANSPORT WHILE ENGINE IS RUNNING.

To transport the machine it is necessary to remove the weight plates.

A. Tilting the Machine

This is a heavy piece of equipment. Caution should be used in tilting the machine. This can be accomplished safely and easily as follows:

1. One man method:

- Standing behind the machine, place one foot on the brace at the base of the propane tank.
- Place one hand on the handle and the other on the "T" frame handle support.
- While pulling and leaning back, lift the other foot off the floor and extend it directly behind. This will shift the balance and naturally tilt the equipment to transport or full "tilt back" position without undue strain.

2. Two man method:

Two people side by side perform the above procedure simultaneously. This is a safer, more comfortable technique to use until more experience is gained with the equipment.



WARNING

Do not use excessive vertical pressure.

B. Position for Maintenance & Cleaning

To perform certain maintenance & cleaning tasks or to change diamonds, the machine should be placed in the full "tilt back" position with weight plates removed. See page 6 for more information about maintenance and cleaning.

PREPARATION

A. Check that the suggested maintenance schedule has been observed. See page 6 for more information about suggested machine and engine maintenance instructions.

All machines are equipped with a multi-function maintenance meter. The functions include the following: hour meter, service alert and tachometer. (See Engine Maintenance Meter instructions on pg. 7).

B. Check the engine oil before every operation.

Make sure the machine is level when checking the oil. Always take 2 readings of the dipstick before adding oil. If the oil level is below the full mark, add just enough oil to the engine to bring the oil level up to the full mark. **Never over fill.** Follow the guidelines in your Engine Owners Manual. Check for foreign material on the dipstick.

C. Properly fill and check your LPG tank and all LPG fuel lines for leaks.

- Every tank has been pressure and leak tested. However, every time a tank is filled and/or connected to the machine it should be soap tested. All LPG lines must be pressurized and every inch of line and connections must be sprayed. If you find a leak, make the proper repairs before operating the machine. NOTE: The connection and disconnection of the LPG tank must be done in a well ventilated area with NO source of ignition within 10 feet (3 meters) from the point of connection.
- Never over fill the LPG tank!** The LPG tank is designed to hold just 20 pounds of propane. Make sure to weigh the tank as it is being filled. The gross weight of a full tank should not exceed 48 pounds. If while operating the machine, you notice frost forming on the LPG lines or the regulator, your tank has been over filled. If you continue to operate the machine in this condition, damage will occur. The excess propane in the tank must be removed before normal operations resume. The bleeding of a propane tank should be done in a safe location outside the building. In some cases the regulator must defrost before restarting the engine.

D. Connecting the high pressure hose to the LPG Tank:

Make sure the couplers are in line and screwed together hand tight. If this is not done properly, fuel will not pass through to the regulator. Never complete the connection of the tanks to the machine by using a wrench. Always do it by hand. Listen for the rush of fuel to the lock-out device when you open the tank valve. If you hear this, it indicates a good connection has been made at the tank



WARNING

NEVER CHANGE OR ALTER THE PROPANE CONTROL EQUIPMENT.

SAFETY

Provide and use ear protection during operation.

Never let an untrained person operate or perform repairs on the machine. They may hurt themselves, damage the floor or the equipment.

Engine speed not to exceed 3400 RPM.

This machine is not suitable for picking up hazardous dust.



WARNING

Do not use on surfaces with a gradient exceeding 2%.

OPERATING PROCEDURES

A. Plate Assembly and Diamond Installation

Resin Bond

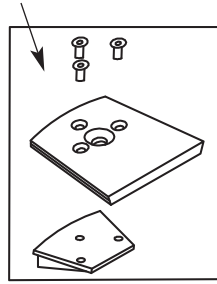

Metal Bond with 3 Screws

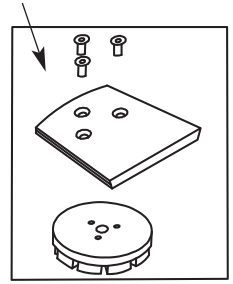

Metal Bond with 1 Screw

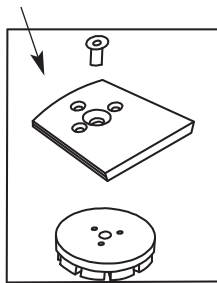

Resin Bond

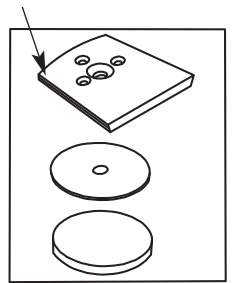

1. Close service valve on fuel cylinder to prevent liquid from getting into the regulator
2. Tilt machine back to access the drive pad
3. Align diamond shoe with slots in drive pad and push firmly into slot
4. Examine red flex plate disc for signs of wear; see daily maintenance requirements

D. Wheel Adjustment

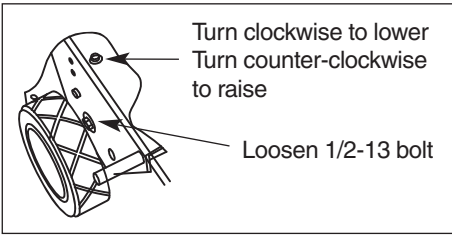

Wheel adjustment must be made to both wheels on level floor.

1. Loosen 1/2-13 bolt
2. Loosen 1/2-13 jam nut just above axle bracket
3. Adjust machine height by turning the 1/2-13 bolt counter clockwise to raise machine or clockwise to lower machine
4. Tighten 1/2-13 jam nut
5. Tighten 1/2-13 bolt

E. Installing the Fuel Cylinder

1. Take UltraEdge to well ventilated area
2. Check cylinder for overfill
3. Place cylinder on the machine in tank holding area and secure the safety strap
4. Connect fuel cylinder to the machine, tighten hand tight. Do not use a wrench or pliers or cross thread
5. Open the service valve slowly, be alert for the odor of propane which may indicate a leak
6. To remove the cylinder, reverse the procedure

F. Before Operating the UltraEdge

- Check oil level
- Check carburetor air filter
- Check diamonds and diamond plates
- Adjust handle height
- Install fuel cylinder in a well ventilated area

G. Before you start the engine



WARNING

Do NOT allow machine to come into contact with loose tiles or other obstructions on the floor. The abrasives will be turning at approximately 650 RPM. If objects are hit, they could become dangerous projectiles!

- Raise the handle and tilt machine back until handle rests on floor.
- Install diamonds.
- Bring machine back to operating position.

H. Starting the engine

1. First - check fuel cylinder for overfill and install cylinder onto machine. Open the tank valve counter-clockwise.
2. Place machine on level surface and check for correct oil level.
3. Attach lanyard kill switch to the operator. Engage the starter by turning the key switch to "Start". Do not run starter for more than 20 seconds at a time. Allow 10-20 seconds between each attempt to start the engine.
4. Increase throttle while walking very slowly.

I. Transporting the machine

1. The tank should be securely fastened.
2. The tank valve must be closed.
3. Weight plates must be removed.

STOPPING THE ENGINE

Turn the propane tank valve clockwise to a closed position and turn the key OFF.

NOTE: The exhaust system will be very hot and takes several minutes to cool, so keep yourself and all materials clear.

MAINTENANCE

A. Gear Box Reducer

Lubrication and Maintenance.

Approved lubricant=Mobilgear 630 GL90

CAUTION: Do not operate the unit without making sure it contains the correct amount of oil. Do not overfill or underfill with oil, or injury to personnel, unit, or other equipment may result. Do not let oil level get below half on the site gauge.

Changing Lubricant- After the first 100 hours of operation, drain out initial oil, flush out the gear case with an approved nonflammable, non-toxic solvent and refill. Thereafter, oil should be changed at least every 2500 operating hours or every 6 months, whichever comes first.

CAUTION: Oil should be changed with greater frequency if unit is used in a severe environment, such as dusty or humid circumstances.



WARNING

Oil housings, and other components can reach high temperatures during operation, and can cause severe burns. Use EXTREME care when removing lubrication plugs and vents while servicing the unit.

B. Cleaning the equipment

1. Place machine in "tilt back" position.
2. Rinse the drive unit and drivers.
3. Rinse around splash skirt and body.
4. Return machine to operating position, then start engine and run machine briefly to expel any excess water.

C. Storing the machine and tank

1. The engine should be stopped properly and the tank valve closed.
2. Remove the LPG tank from the machine and store the tank in a well ventilated approved area.
3. Store your machine in a safe area: away from enclosed high heat, away from sparks or flames, and away from traffic lanes of heavy equipment.

D. Machine & Engine Maintenance

1. Refer to engine manufacturer's Owners Manual and comply completely with the instructions. Change the oil and filter according to the engine Owners Manual.
2. Keep a good service log on each machine with the date, hour meter reading, type(s) of service performed and the name of the person who performed them.
3. Clean the entire unit after each use. When cleaning the unit, check for possible loose nuts and bolts.

E. Maintenance Schedule

Repairs and adjustments to the fuel system must be performed by an authorized, properly trained service technician. To keep the machine in good working condition, follow the daily, weekly and monthly maintenance procedures listed below. Keeping the machine clean and free of accumulated dust, lint and oil allows free air to flow across the engine and proper cooling. Always use clean recoil dust filters. These can be cleaned by washing them in flowing water and shaking them dry. Keep a log book of maintenance and/or repairs.

Daily Maintenance

Every two hours of operation:

Change or vacuum clean the recoil dust filter.

Check and clean carburetor pre-filter.

Every four hours of operation:

Check oil level.

Make sure all components (shroud, handle, fuel cylinder, belt, etc) are tight and secure.

Check drive plates and flex material for cracks or diamond wear.

Clean machine – if compressed air is available, blow dust from machine and engine, concentrating on the inside of engine shrouds, and wash undercarriage.

Weekly Maintenance: every 20–50 hours of operation

Perform all daily maintenance services.

Change oil and oil filters at 50 hours of service.

Check for loose nuts and bolts on entire machine.

Examine all propane fuel components for leaks or wear, replace if necessary.

Monthly Maintenance: every 80 hours of operation

Perform all daily and weekly services.

Change carburetor air filter.

Consult engine owner's manual for maintenance services.

Quarterly Maintenance: every 250 hours of operation

Perform all daily, weekly and monthly services.

Have engine checked by an authorized service center professionals.

Have engine emissions checked by an authorized service center professionals.

Servicing the UltraEdge

Proper maintenance of the UltraEdge is the responsibility of the owner and/or the operator. Be sure to go through this checklist on a regular basis:

Check oil level.

Check and clean air and dust filters.

Keep machine clean and lubricated.

Clean entire machine after each use. Engine must be cool before water is used to prevent warping and other damage.

Clean carburetor air filters after four hours running time, and clean or replace daily before operation.

Check for wear on drive plates and flex hubs daily, replace if damaged.

Promptly report any damaged or worn parts to supervisor.

Servicing and adjusting of the propane fuel system should only be done by a trained, authorized professional.



WARNING

Never attempt to adjust the fuel system of a propane engine! If equipped with an emission monitoring or controlling system, never attempt to disconnect or circumvent it. Promptly report problems to supervisor.

E. Engine Maintenance Meter

This multi-function meter acts as a preventive maintenance tool, which benefits you with increased fuel economy, less down-time and longer engine life.

The meter's displays are:

Hour Meter: Displays total run hours when machine is off.

Tachometer: Indicates engine RPM during operation.

Service Alert: The display flashes to alert you to lube and change the oil at 25 hour intervals. The service alert only flashes during operation and it warns you to change the oil for only two hours. After the two hours is reached, the alert will automatically reset to the next 25 hour interval. Therefore, it is recommended that a separate maintenance log be kept to track oil changes.



WARNING

Remember that being safe is a full-time, every day job. Follow all information posted on the machine and the LPG tank.

Never allow anyone to operate this machine who has not read or cannot understand the given instructions.

F. Troubleshooting the electrical system

1. Check all wire connections for obvious problems. Remove LPG tank, then remove battery box cover. Check all connections visibly and physically. If any "loose", damaged or unconnected wires are noticed, replace or repair as needed.
2. Check the battery posts and wires. **Always wear a face shield, safety glasses and protective clothing when working around a battery.** The gases can be explosive and the acid is highly corrosive to metals, cloth and ALL HUMAN TISSUE (skin, eyes, etc.) If the battery post(s) are corroded, remove the wires and clean posts and wires. Applying some axle grease on the posts of the battery after they are cleaned will slow down the battery corrosion process.

If nothing obvious is noted, a more detailed investigation is warranted. Before any such troubleshooting begins, the following things should be done:

- a. Replace propane LPG tank with one from a machine that runs.
- b. Charge the battery or provide an absolute source of 12 volt DC power capable of 50 amperes total output. (A pair of good jumper cables from your car or truck battery will suffice.) Equip yourself with an inexpensive 12 volt test light.
- c. If the trouble seems to be in the electrical control equipment, you may disconnect the starter from the system so as to check the system without spinning the engine.
- d. Battery rundown. A common problem is letting the battery run down. What usually happens is that it takes the crew a few jobs to get used to the whole system, so the machine is stopped and started quite often. Key left in On position, when engine is turned off, will result in battery running down—dying.

KAWASAKI 603cc ENGINE**Tune-up Specifications**

| ITEM | SPECIFICATIONS |
|-----------------|--|
| Ignition Timing | Unadjustable |
| Spark Plugs: | NGK BPR4ES |
| Gap | 0.75 mm (0.30 in) |
| Low Idle Speed | 1550 RPM |
| High Idle Speed | 3400 MAX RPM |
| Valve Clearance | IN: 0.10-0.15 mm (0.004-0.006 in) EX: 0.10-0.15 mm (0.004-0.006 in) |

NOTE: High and low idle speeds may vary depending on the equipment on which the engine is used. Refer to the equipment specifications.

Engine Oil

Check the engine oil daily before starting the engine otherwise shortage of the engine oil may cause serious damage to the engine such as seizure.

- Place the engine on a level surface. Clean the area around the oil gauge before removing it.
- Remove the oil gauge and wipe it with a clean cloth.
- Pour the oil slowly to "FULL" mark on the oil gauge.
- Insert the oil gauge into the tube **WITHOUT SCREWING IT IN.**
- Remove the oil gauge to check the oil level. The oil level should be between "ADD" and "FULL" marks. Do not overfill.
- Install and tighten the oil gauge.

Recommended Oils

The following engine oils are recommended.
API Service Classification: SF, SG, SH, or SJ.

Oil Viscosity

Choose the viscosity according to the temperature as follows:

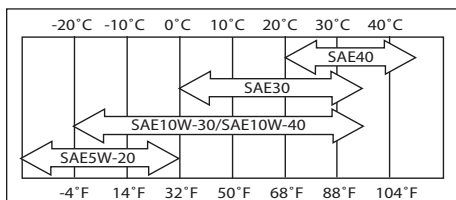

NOTE: Using multi grade oils (5W-20, 10W-30, and 10W-40) will increase oil consumption. Check oil level more frequently when using them.

Engine Oil Capacity

FS481V | 1.7 L (1.8 US qt.) when oil filter is removed

Oil Change

Change oil after **first 8 hours of operation.** Thereafter change oil **every 50 hours.**

- Run the engine to warm oil.
- Be sure the engine (equipment) is level.
- Stop the engine.
- Open the oil drain valve and drain the oil into suitable container while engine is warm.

⚠ WARNING!

Hot engine oil can cause severe burns. Allow engine temperature to drop from hot to warm level before draining and handling oil.

Oil Drain Plug

- Close the oil drain valve.
- Remove oil gauge and refill with fresh oil (See "Recommended Oils").
- Check the oil level (see "Preparation" on page 3 for oil level check).

Oil Filter Change

- Change the oil filter **every 100 hours of operation.**

⚠ WARNING!

Hot engine oil can cause severe burns. Allow engine temperature to drop from hot to warm level before attempting to remove oil filter.

CAUTION! Before removing the oil filter, place a suitable pan under filter connection.

- Drain engine oil into a suitable container.
- Rotate the oil filter (A) counterclockwise to remove it.

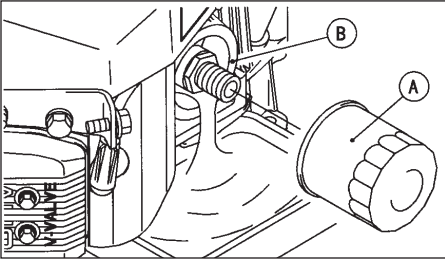

- Coat a film of clean engine oil on seal of new filter.
- Install new filter rotating it clockwise until seal contacts mounting surface (B). Then rotate filter 3/4 turn more by hand.

- Supply engine oil as specified.
- Run the engine for about 3 minutes, stop engine, and check oil leakage around the filter.
- Add oil to compensate for oil level drop due to oil filter capacity (See "Preparation" for oil level check on pg. 3).



WARNING

Engine oil is a toxic substance. Dispose of used oil properly. Contact you local authorities for approved disposal methods or possible recycling.

KAWASAKI ENGINE MAINTENANCE SCHEDULE

| MAINTENANCE | INTERVAL | | | | | | |
|--|----------|-------------|--------------|--------------|---------------|---------------|---------------|
| | Daily | First 8 hr. | Every 25 Hr. | Every 50 hr. | Every 100 hr. | Every 200 hr. | Every 300 hr. |
| Check and add engine oil | • | | | | | | |
| Check for loose or lost nuts and screws | • | | | | | | |
| Check for fuel and oil leakage | • | | | | | | |
| Check or clean air intake screen | • | | | | | | |
| Clean air cleaner foam element | | | • | | | | |
| Clean air cleaner paper element | | | | • | | | |
| Clean dust and dirt from cylinder and cylinder head fins | | | | | • | | |
| Tighten nuts and screws | | | | | • | | |
| Change engine oil | | • | | • | | | |
| Clean and gap spark plugs | | | | | • | | |
| Change oil filter | | | | | • | | |
| Replace air cleaner paper element | | | | | • | | |
| Clean combustion chambers | | | | | | | • |
| Clean and adjust valve clearance | | | | •* | | | • |
| Clean and lap valve seating surface | | | | | | | • |

*After the 1st 50 hours

KAWASAKI ENGINE BATTERY START WIRING DIAGRAM

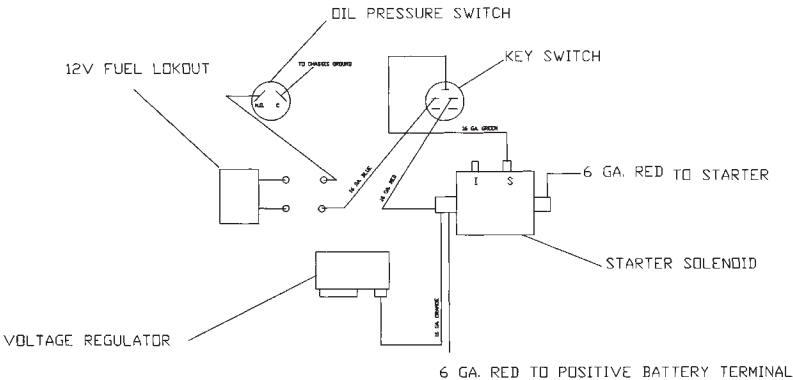

ENGINE TROUBLESHOOTING

| COMMON PROBLEMS & PROBABLE CAUSES | SOLUTIONS |
|---|--|
| <p>Engine cranks but will not start</p> <ul style="list-style-type: none"> • Fuel cylinder is empty • Shutoff valve is closed • Clogged, obstructed, kinked or cut fuel or vacuum line • Spark plug lead disconnected • Faulty choke or throttle settings • Faulty ignition coil • Faulty kill switch • Faulty regulator | <p>Refill cylinder Open valve Remove obstruction or replace line Connect lead to spark plug Set controls to correct positions Replace coil Replace switch Replace regulator</p> |
| <p>Engine starts hard</p> <ul style="list-style-type: none"> • Faulty choke or throttle settings • Clogged, obstructed, kinked or cut fuel or vacuum line • Faulty regulator • Low compression | <p>Set controls to correct position Remove obstruction or replace line Replace regulator Have engine serviced by a trained technician</p> |
| <p>Engine will not crank</p> <ul style="list-style-type: none"> • Battery is discharged • Loose or faulty connections or wires • Faulty ignition key switch or starter control switch | <p>Charge or replace battery Tighten, repair or replace wires Repair or replace switch(es)</p> |
| <p>Engine overheats</p> <ul style="list-style-type: none"> • Incorrect fuel settings • Air intake filter screen or cooling fins clogged • Low oil level | <p>Have engine serviced Clean and clear debris or replace filter Check and add oil</p> |
| <p>Exhaust emissions or propane odor</p> <ul style="list-style-type: none"> • Carburetor or regulator setting incorrect • Dirty or clogged air filter • Choke engaged • Loose fittings, clamps or hoses cracked, hoses cut or leaking | <p>Have engine serviced by a trained technician Replace air filter Adjust to correct settings Tighten or seal; check with soap and water solution, if bubbles appear, part is still leaking; replace</p> |

BODY ASSEMBLY PARTS

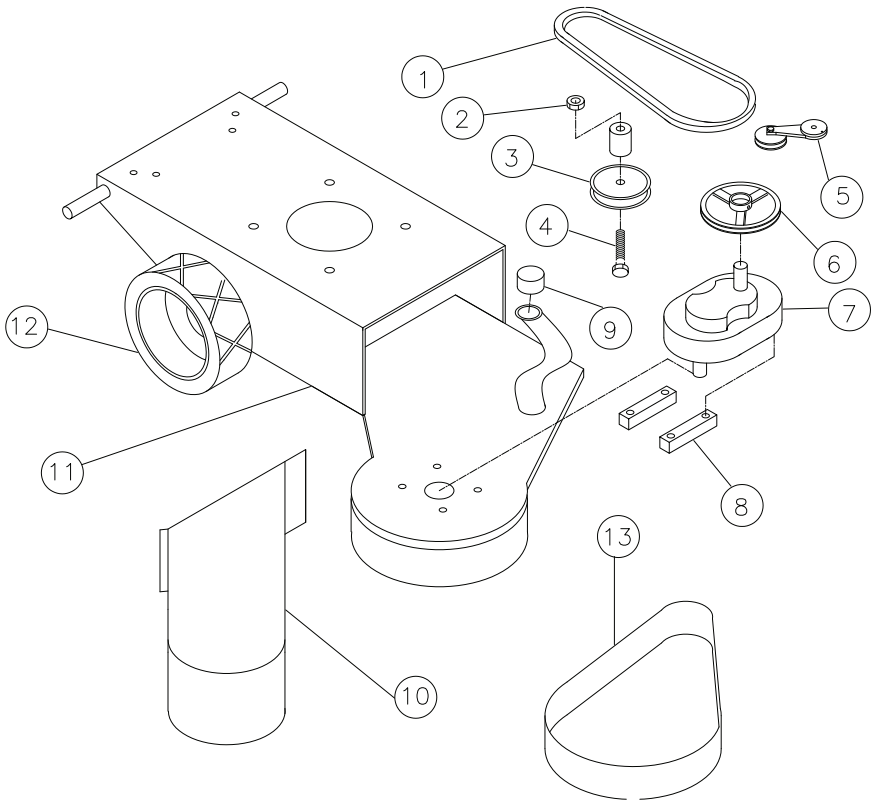

| REF | DESCRIPTION | PART # | QTY |
|------------|--------------------|-----------------|------------|
| 1 | BELT | 113-BP72 | 1 |
| 2 | 1/2-13 LOCK NUT | 164-22836 | 1 |
| 3 | FLAT IDLER PULLEY | 041-BA-02P | 1 |
| 4 | 1/2-13X3 BOLT | 164-JOC300HCS5Z | 1 |
| 5 | BELT TENSIONER | 011-6-2795 | 1 |
| 6 | PULLEY (GEAR BOX) | 172-041 | 1 |
| 7 | GEAR BOX | 041-953 | 1 |
| 8 | SPACER BLOCK | 283-041-20 | 2 |
| 9 | VACUUM CAP | 040-3015 | 1 |
| 10 | BELT COVER | 288-041-300 | 1 |
| 11 | BODY ASSEMBLY | 288-041-100 | 1 |
| 12 | WHEEL ASSEMBLY | 156-040 | 2 |
| 13 | DUST/SPLASH SKIRT | 041-100 | 1 |

HANDLE ASSEMBLY PARTS

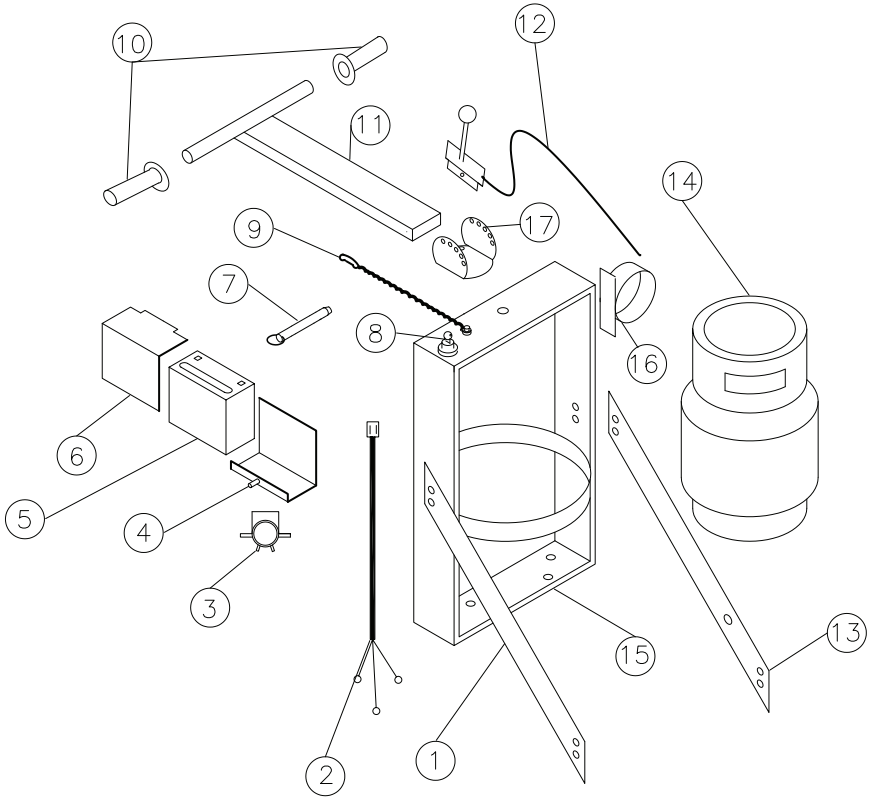

| REF | DESCRIPTION | PART # | QTY |
|------------|--------------------------|---------------|------------|
| 1 | HANDLE STRUT | 283-040-600 | 1 |
| 2 | WIRE HARNESS | 011-762WHK | 1 |
| 3 | STARTER SOLENOID | 296-SS-581 | 1 |
| 4 | BATTERY BOX BOTTOM | 283-11-2127B | 1 |
| 5 | BATTERY 12V | 276-GTX14 | 1 |
| 6 | BATTERY BOX TOP | 283-11-2127T | 1 |
| 7 | LOCK PIN | 625-98404A385 | 1 |
| 8 | KEY SWITCH | 312-308-0385 | 1 |
| 9 | LANYARD KILL SWITCH | 153-73459 | 1 |
| 10 | HANDLE GRIP | 224-1 | 2 |
| 11 | T-HANDLE | 283-025-600 | 1 |
| 12 | THROTTLE CABLE | 196-60314 | 1 |
| 13 | HANDLE STRUT W/OIL DRAIN | 283-041-600 | 1 |
| 14 | 20# LP CYLINDER | 293-20# STLMF | 1 |
| 15 | HANDLE BASE ASSEM. | 288-041-400 | 1 |
| 16 | VAC HOSE GUIDE BRKT. | 288-041-700 | 1 |
| 17 | SWIVEL BRACKET ASSEM. | 288-041-300 | 1 |

WHEEL AXLE ASSEMBLY PARTS

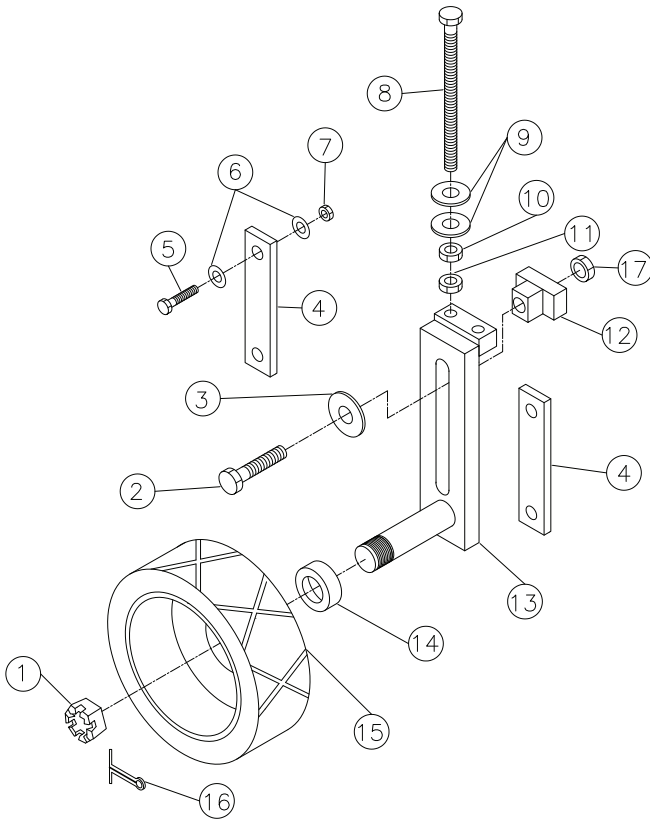

| REF | DESCRIPTION | PART # | QTY |
|------------|------------------------|-----------------|------------|
| 1 | AXLE NUT | 164-36869 | 2 |
| 2 | 1/2-13X2 HCS | 164-110120382 | 2 |
| 3 | 1/2" FLAT WASHER | 164-20159 | 2 |
| 4 | ADJUSTMENT SIDE BAR | 283-040-1000 | 4 |
| 5 | 3/8-16X1 HCS | 164-10115 | 8 |
| 6 | 5/16" FLAT WASHER | 164-20156 | 16 |
| 7 | 3/8-16 STOVER LOCK NUT | 164-22834 | 8 |
| 8 | 1/2-13X5" BOLT | 164-50C500BTA5Z | 2 |
| 9 | 1/2" FLAT WASHER | 164-20159 | 4 |
| 10 | 1/2-13 STOVER LOK NUT | 164-22836 | 2 |
| 11 | 1/2-13 HEX NUT | 164-22008 | 2 |
| 12 | T-SLOT NUT | 164-731-54338 | 2 |
| 13 | AXLE BRACKET ASSEM. | 288-041-15 | 2 |
| 14 | AXLE SPACER | 040-3010 | 2 |
| 15 | WHEEL ASSEMBLY | 156-040 | 2 |
| 16 | COTTER PIN | 164-18R200PC0Z | 2 |
| 17 | 1/2-13 NYLOK NUT | 164-22514 | 2 |

DIAMOND DRIVERS PARTS

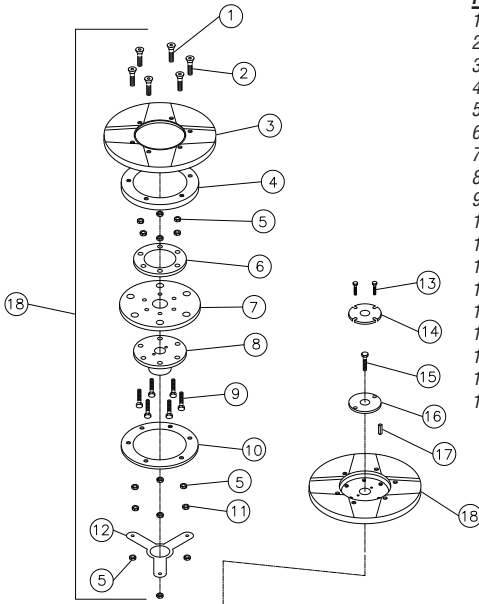

| REF | DESCRIPTION | PART # | QTY |
|-----|-----------------------|-----------------|-----|
| 1 | 3/8-16X2¼ FSCS | 164-37C225KSCST | 3 |
| 2 | 3/8-16X2½ FSCS | 164-37C25KSC | 3 |
| 3 | DRIVE PLATE | 283-040-2255 | 1 |
| 4 | MOUNT SPACER | 283-040-2220 | 1 |
| 5 | 3/8-16 STOVER LOK NUT | 164-22834 | 12 |
| 6 | HUB RING | 283-040-2215 | 1 |
| 7 | FLEX PLATE | 040-2210 | 1 |
| 8 | HUB | 283-040-2230 | 1 |
| 9 | 3/8-16X1¼ HCS | 164-10117-SS | 6 |
| 10 | MOUNT RING | 283-040-2245 | 1 |
| 11 | 3/8-16 HEX NUT | 164-22004 | 3 |
| 12 | SAFETY STRAP | 283-040-2225 | 1 |
| 13 | 5/16-18X1 HCS | 164-110120325 | 2 |
| 14 | SHAFT LOCK PLATE | 283-040-2240 | 1 |
| 15 | 3/8-16X1¼ HCS | 164-10117-SS | 1 |
| 16 | SHAFT END PLATE | 283-040-2235 | 1 |
| 17 | ¼" KEY | 199-NHNT-SE UND | 1 |
| 18 | DRIVE PLATE ASSEMBLY | 041-2255 | 1 |

KAWASAKI 603cc ENGINE

| REF | DESCRIPTION | PART # | QTY |
|-----|---------------------|-----------------|-----|
| 1 | FOAM HAT | 186-271964 | 1 |
| 2 | DEBRIS SCREEN | 309-18540-603 | 1 |
| 3 | DEBRIS SCREEN SEAL | 175-8.25*9.75 | 1 |
| 4 | OIL PRESSURE SWITCH | 152-N3-0082 | 1 |
| 5 | OIL FILTER | 309-49065-7007 | 1 |
| 6 | OIL DRAIN DRIVE | 312-504-0185 | 1 |
| 7 | ¼" KEY | 199-NHNT-SE UND | 1 |
| 8 | CENTRIFUGAL CLUTCH | 311-180007 | 1 |
| 9 | ½" FLAT WASHER | 164-20159 | 1 |
| 10 | 7/16-20X1 HCS | 164-10301 | 1 |
| 11 | EXHAUST GASKET | 309-11060-7016 | 2 |
| 12 | EXHAUST MANIFOLD | 152-603-MAN | 1 |
| 13 | MUFFLER | 152-603-MUF | 1 |
| 14 | PRE FILTER | 309-11013-7046 | 1 |
| 15 | AIR FILTER | 309-11013-7049 | 1 |

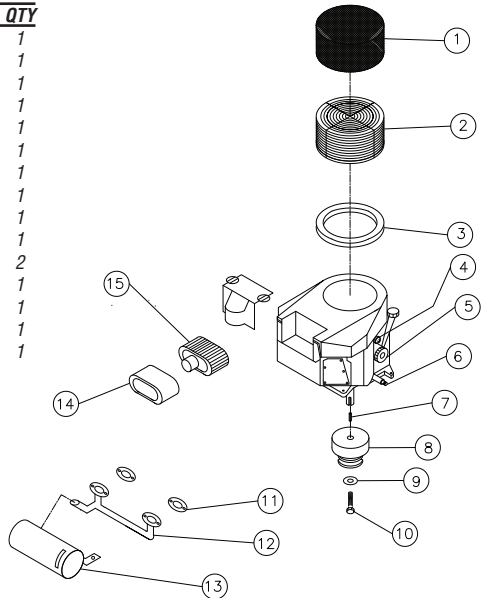

FUEL SYSTEM PARTS

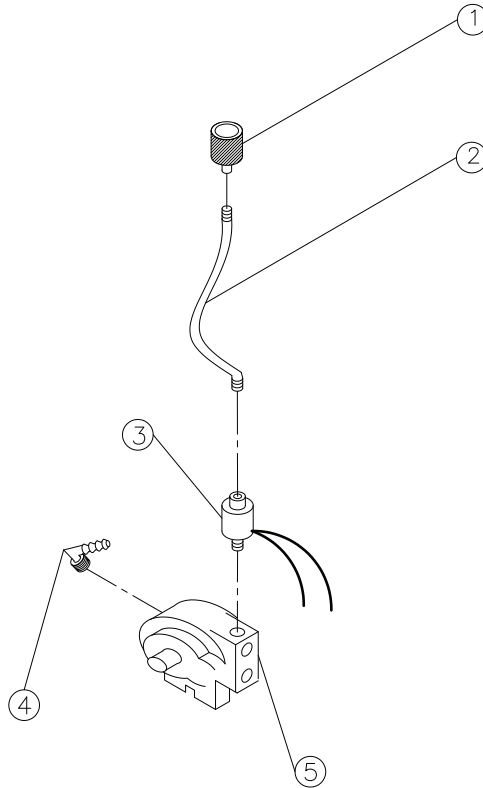

| REF | DESCRIPTION | PART # | QTY |
|------------|--------------------|----------------|------------|
| 1 | QUICK CONNECT | 152-700 | 1 |
| 2 | LPG HOSE 20" | 267-P5561-0410 | 1 |
| 3 | FUEL LOCK OUT 12V | 152-N3-0173-1 | 1 |
| 4 | HOSE BARB FITTING | 166-62039 | 1 |
| 5 | LPG REGULATOR | 152-500 | 1 |

ULTRAEDGE WARRANTY

This quality product is warranted to be free from defects in workmanship and materials. The warranty is limited as follows:

| Component | Term of Warranty |
|--------------------|---|
| Engine | 2 yrs from engine manufacturer |
| Fuel System | 1 yr |
| LP Tank | 1 yr on valve, 3 yrs on cylinder from date of mfgr. |
| Body Parts | 1 yr |
| Battery | 1 yr from battery mfgr. |
| Centrifugal Clutch | 1 yr |
| Bearings | 6 months |
| Drive Blocks | 6 months |

The warranty does not apply to certain consumable or wear parts such as:

*Belts
Engine tune up parts*

All engines are warranted by the manufacturer (Kawasaki) for a period of two years when engine maintenance schedules are followed.

Aztec Products, Inc. agrees, at its discretion, to repair or replace at its own expense any product or part(s) which examination proves to be defective in workmanship or materials provided that the purchaser notifies Aztec Products, Inc. directly within the warranty period and follows the Return Goods Policy. Engine repairs may be performed at engine manufacturer's service centers. For your closest center you may call the following number:

Kawasaki 616-949-6500

The warranty does not apply to damage or failure caused by abuse, misuse, neglect, disassembly, alteration, unauthorized modification, lack of proper maintenance, theft, or damage by freight carriers. The warranty applies to parts, labor and ground freight only. It does not cover incidental or consequential damages.

In order to obtain parts warranty, the following procedures must be followed:

- 1. Customer must call Aztec Products, Inc. for an RGA (Return Goods Authorization) Number.*
- 2. We maintain the serial number, date of shipment or sale, and customer name on each piece of equipment sold. If you were the purchaser, please reference that information on your request for replacement or repair. If you purchased the equipment through a distributor, please contact them first. If you are not satisfied, contact Aztec and give us the distributor name, purchase date, and the serial number of the product.*
- 3. The defective part must be returned via ground freight prepaid to Aztec Products, Inc. with an RGA number accompanied by a copy of the original purchase invoice. Aztec is not responsible for the cost of packaging inbound freight, nor inbound freight damage. Pack machine carefully.*
- 4. Only Aztec Products, Inc. or its authorized dealers may make warranty repairs on Aztec Products, Inc. products. Others do so at their own risk and expense.*
- 5. We also offer to do warranty related repairs free of charge at our facility. Arrangements must be made in advance as outlined above. We will not accept freight collect returns or returns that do not indicate the RGA number on the packing list.*

The need for proper maintenance and care for this product cannot be overstated. Poor maintenance, neglect or abuse can prove to be very expensive.

You have purchased a quality product. Each of its components has been tested and approved for use by Aztec Products, Inc. It is unlikely that you will ever have a warranty claim if you properly maintain our machine.

This warranty is non-transferable.

AZTEC PRODUCTS, INC.

201 Commerce Drive • Montgomeryville, PA 18936 • 800-331-1423 • Fax 215-393-4800