

OWNER'S MANUAL

THE REFRESHER 30"

Concrete, Terrazzo & VCT Restoration System



LOWEST EMISSIONS IN THE INDUSTRY
CARB, CE, EPA & LEED CERTIFIED PROPANE

EQUIPMENT DISTRIBUTOR: _____
DIST. SALESPERSON: _____ PHONE #: _____
DATE OF PURCHASE: _____ INVOICE #: _____



WWW.AZTECPRODUCTS.COM

PARTS@AZTECPRODUCTS.COM

201 COMMERCE DRIVE, MONTGOMERYVILLE, PA 18936

TABLE OF CONTENTS

GENERAL OPERATIONS

TABLE OF CONTENTS	PG 2
INTRODUCTION	PG 3
SAFETY MESSAGE INFORMATION	PG 3
RESPIRATORY HAZARD INFORMATION	PG 4
GRAPHICAL SYMBOLS & PRODUCT LABELS	PG 4
IMPORTANT SAFETY INSTRUCTIONS	PG 5
GENERAL OPERATION SAFETY INFORMATION	PG 5-8
STORAGE AND HANDLING SAFETY INFORMATION	PG 9
BEFORE OPERATION CHECKLIST	PG 10-11
STARTING/STOPPING THE ENGINE	PG 12
CONTROL LEVER	PG 12
SETTING ENGINE SPEED	PG 12
OPERATION	PG 13
ENGINE MAINTENANCE METER	PG 14
TRANSPORTING THE MACHINE	PG 14
INSTALLING PADS, BRUSHES, RESINS, HYBRIDS	PG 14-15
MACHINE CLEAN-UP	PG 15
STORING THE MACHINE & PROPANE TANKS	PG 16
TROUBLESHOOTING ELEC SYSTEM & DRIVE BELT	PG 16-17
NOTES	PG 17
ENGINE OIL & MAINTENANCE	PG 18-20
ENGINE MAINTENANCE SCHEDULE	PG 20
ENGINE TROUBLESHOOTING	PG 21
BATTERY START WIRING DIAGRAM	PG 21
ENGINE TUNE-UP SPECIFICATIONS	PG 21
QUICK START GUIDE	PG 22
WARNING LABEL LOCATIONS	PG 23

ASSEMBLY DRAWINGS & PARTS DIAGRAMS

REPLACEMENT PARTS & PREVENTATIVE MAINTENANCE KIT INFO	PG 24
REGULATOR, DRIVE BELT & PROPANE TANK	PG 25
DECK ASSEMBLY	PG 26-27
HANDLE ASSEMBLY	PG 28-29
SOLUTION TANK ASSEMBLY	PG 30
DRIVE UNIT ASSEMBLY	PG 31
INPUT PULLEY ASSEMBLY	PG 32
GEARBOX ASSEMBLY	PG 33-34
TENSIONER ASSEMBLY	PG 35
TRANSPORT WHEEL ASSEMBLY	PG 36
REGULATOR ASSEMBLY	PG 37
ENGINE DIAGRAM	PG 38-39
DIAMOND DRIVER DIAGRAM	PG 40
PAD DRIVER DIAGRAM	PG 41
STRIP BRUSH DIAGRAM	PG 42
ELECTRICAL SCHEMATIC	PG 43
WARRANTY	PG 44

INTRODUCTION

Thank you for purchasing this Aztec Products, Inc. machine. You have purchased a quality product and we welcome you to the Aztec family. It is critically important to utilize proper training, understanding, maintenance and care for this product. Neglect of the Safety Messages, especially the **DANGER, WARNING, CAUTION** and **NOTICE** statements throughout this Owner's Manual may lead to serious injury or death, and/or cause damage to the floor and/or facility.

For best results from your Aztec machine, you must read and understand this Owner's Manual, and follow all operation guidelines and safety messages. Protect your **WARRANTY** by following all maintenance guidelines and keeping a dated log. If a problem should arise, consult an authorized Aztec service center.

All information in this Owner's Manual is up to date and based on the latest product information available at the time of printing. Aztec Products, Inc. reserves the right to make changes at any time without notice or incurring obligation. This Owner's Manual and the maintenance log must be kept as a permanent part of the machine and remain with the machine if resold.

No part of this document may be copied or reproduced without written permission.

SAFETY MESSAGE INFORMATION

Your safety and the safety of others is very important. As the manufacturer, we have provided important safety messages throughout this manual and on the machine. The purpose of these safety messages is to prevent damage to you, your machine, the property, and/or the environment.

Please read and understand this information thoroughly. A safety message alerts you to potential hazards that could result in injury or death, and/or cause damage to the floor and/or facility. Each safety message is preceded by a universal safety alert symbol (!) and one of these safety words: **DANGER, WARNING, CAUTION**, or **NOTICE**. These signal words mean:

	DANGER indicates a hazardous situation which, if not avoided, will result in death or serious injury
	WARNING indicates a hazardous situation which, if not avoided, could result in death or serious injury.
	CAUTION indicates a hazardous situation which, if not avoided, could result in minor or moderate injury
	NOTICE is used to address practices not related to physical injury



Wear approved respiratory protection when the machine is operating.



RESPIRATORY HAZARD INFORMATION:

Grinding/cutting/drilling of masonry, concrete, metal and other materials can generate dust, mists and fumes containing chemicals known to cause serious or fatal injury or illness, such as respiratory disease, cancer, birth defects or other reproductive harm. If you are unfamiliar with the risks associated with the particular process and/or material being cut or the composition of the tool being used, review the material safety data sheet and/or consult your employer, the material manufacturer/supplier, governmental agencies such as OSHA, EU-OSHA and NIOSH and other sources on hazardous materials. California and other authorities, for instance, have published lists of substances known to cause cancer, reproductive toxicity, or other harmful effects.

Control dust, mist and fumes at the source where possible. In this regard use good work practices and follow the recommendations of the manufacturers or suppliers, OSHA, NIOSH, and occupational and trade associations. Water should be used for dust suppression when wet cutting is feasible. When the hazards from inhalation of dust, mists and fumes cannot be eliminated, the operator and any bystanders should always wear a respirator that is approved for the materials being used.

SILICOSIS WARNING INFORMATION:

Grinding/cutting/dripping of masonry, concrete, metal and other materials with silica in their composition may give off dust or mists containing crystalline silica. Silica is a basic component of sand, quartz, brick clay, granite and numerous other minerals and rocks. Repeated or substantial inhalation of airborne crystalline silica can cause serious or fatal respiratory diseases, including silicosis. When using the equipment with such materials, always follow all dust control and respiratory precautions.

GUIDE TO GRAPHICAL SYMBOLS AND PRODUCT LABELS



DANGER, WARNING OR CAUTION; read all instructions before using



Hot surface – Do not touch



Wear hearing protection when operating



Wear safety goggles when operating



Switch "On" Position



Switch "Off" position

IMPORTANT SAFETY INSTRUCTIONS

READ and UNDERSTAND all instructions and safety messages before operating this machine.

Follow the instructions given in this Owner's Manual and the training given by your supervisor for the safe operation of this machine. Failure to do so can result in personal injury and/or damage to the machine or property.

GENERAL OPERATION SAFETY INFORMATION

Liquefied petroleum gas (LPG or propane) is stored under pressure and must be handled in the proper manner to be safe. Observe the following safety messages to get the best performance, lowest emissions, and longest life out of your equipment.

NOTICE

The EPA has rated the PurePowerLPG™ 600 Series engine cleanest in the industry for CO (carbon monoxide) emissions. (Source: <https://www3.epa.gov/otaq/certdata.htm#smallsi>).

⚠ DANGER

Because CO is always a byproduct of internal combustion engines, it is important to know the symptoms of CO exposure, which may include drowsiness, dizziness, nausea, vomiting, confusion, collapse, loss of consciousness and muscle weakness. If such symptoms occur during operation with this machine, immediately shut off the machine and go outside for fresh air. Have a qualified service technician test the machine for CO emissions before using again. Call for emergency medical attention and DO NOT operate this machine or other propane powered equipment until cleared by a physician. For more info on CO exposure effects, see <http://www.mayoclinic.org/diseases-conditions/carbon-monoxide/basics/symptoms/con-20025444>.

⚠ DANGER

No smoking, no sparks, no flames near machine, engine or LPG tank. Do not operate this machine in an environment with a potential ignition source.

⚠ DANGER

If you smell gas: immediately stop the unit, check for leaks, open windows, don't touch electrical switches, extinguish any open flames, and contact a repair professional.

⚠ DANGER

Never change or alter the propane control equipment. It is precisely tuned to power machinery with minimal levels of carbon monoxide. Altering the control equipment could cause dangerous levels of engine emissions.

⚠ DANGER

Effective January 1, 2016, all Aztec Products, Inc. machinery is shipped with propane tank equipped with Overfill Protection Device (OPD). If you have an older LPG cylinder that is overfilled, always vent outdoors, away from closed areas where gas may accumulate, and away from any fire, flame, or spark-producing device. Use a screwdriver to vent excess propane, which escapes as a white mist. Propane will vent clear when correct tank level has been achieved.

⚠ DANGER

All Aztec propane powered machines are designed specifically for use with a 20 lb (5 gallon) vertical vapor withdrawal propane cylinder. Use of a different configuration cylinder or liquid withdrawal cylinder is dangerous and could cause fire or explosion, and will void the warranty.

⚠ DANGER

Because of the weight of this machine, a second person should assist the tilting back of the machine before any work is done on the underside of the machine. Refer to **TRANSPORTING THE MACHINE** on page 14 to properly tilt back and secure machine.

⚠ WARNING

Operate only in well ventilated areas. Buildings must be provided with:

- A. A continuous mechanical ventilation that removes the products of combustion to the outdoors of not less than 300 CFM for each 10,000 BTUH or fraction thereof; or
- B. Natural ventilation of not less than 300 CFM for each 10,000 BTUH input or fraction thereof, based on a maximum of one-quarter air exchange per hour for the net building volume.

⚠ WARNING

Although this machinery utilizes a catalytic muffler to treat and minimize all engine emissions, the exhaust may still contain trace amounts of chemicals known in the state of California to cause cancer, birth defects or other reproductive harm.

⚠ WARNING

Keep hands and feet clear of moving parts to avoid injury.

⚠ WARNING

Machine should only be tipped back for service if properly turned OFF, in a safe environment and positioned on a flat surface. Do not tilt machine on its side; damage can occur to the machine, furniture, buildings and/or personal injury.

⚠ WARNING

Before attempting any service or maintenance, the engine switch must be in the OFF position and the propane tank valve must be in CLOSED position.

⚠ CAUTION

Never let an untrained or irresponsible person operate the machine. They may hurt themselves and/or damage the floor or other property.

⚠ CAUTION

Always check oil before attempting to start engine. Low oil may result in serious and expensive engine damage.

⚠ CAUTION

Never complete the connection of the propane tank to the machine by using a tool; always tighten and loosen by hand. Use of tools to tighten or loosen tank connection may result in damage to tank valve and insecure connection. Listen for the rush of fuel to the lock-out device when you open the tank valve. If you hear this, it will indicate that a good connection has been made at the tank.

⚠ CAUTION

Muffler is HOT. Keep all heat sensitive objects away from the exhaust system during and after operation. Damage can occur to the machine, furniture, buildings and/or personal injury.

⚠ CAUTION

Do not leave this machine unattended while the engine is running. Damage to floor surface or other property may occur and fumes may accumulate.

⚠ CAUTION

Do not operate machine in a stationery spot for more than a few seconds. Machine is designed to be moved continuously forward at a measured pace. Stationary operation will result in damage to floor surface.

⚠ CAUTION

When the LPG tank is attached to the machine and not running, the tank valve must be in the CLOSED position.

⚠ CAUTION

Grease the pillow block bearing every 10 hours for best results. The pillow block bearing is part of the lower brush drive assembly. Failure to do so will void your warranty. See page 32 for diagram.

⚠ CAUTION

Do not use the "T" handle as a lever when attempting to tilt back machine for service or cleaning. The "T" handle is designed for control during operation only. To tilt back machine, place one foot on the propane tank base bar, one hand on the handle base, and one hand on the "T" handle. Pull back and down from the handle base, and push down with your foot, using the "T" handle only to control lateral motion.

NOTICE

The manufacturer's warranty will be voided if the machine is not maintained in accordance with this manual's recommended maintenance instructions and the engine manufacturer's recommended maintenance procedures. Failure to do so may cause damage to the machine, equipment, furniture, buildings and/or personal injury.

NOTICE

An abbreviated, quick reference schedule of the manufacturer's suggested maintenance is on the underside of the handle. This abbreviated schedule is for quick reference only and is not intended to replace the full maintenance schedule in the Owner's Manual.

NOTICE

A maintenance record must be kept, indicating all dates of service, hours on engine at time of service, and service performed in order to maintain manufacturer's warranty coverage. Perfect record keeping does not guarantee warranty coverage if the damage to the machine is non-warrantable. See warranty coverage policy details at the end of this Owner's Manual. The maintenance record must be kept with the machine and transferred to the new owner if resold.

NOTICE

Using the electric starter for more than 5 seconds at a time will overheat the starter motor and can damage it.

NOTICE

A "NO SMOKING" sign should be permanently displayed at the storage area.

NOTICE

Do not remove machine/engine labels and/or WARNING stickers on machine or engine. If any labels or stickers come lose, contact Aztec (parts@aztecproducts.com) for replacement.

NOTICE

Your new propane powered machine includes a new, empty, vertical LPG propane tank with OPD (Overfill Prevention Device). This is a safety shutoff device incorporated into the filling valve of the propane tank. The OPD valve is designed to prevent cylinder overfilling in excess of the cylinder's maximum permitted filling limit. This valve is provided by the LPG tank manufacturer and may malfunction. The OPD is not to be relied upon in filling the LPG tank; the propane tank is to be filled by weight or by use of a fixed liquid level gauge. The OPD is a backup safety device only.

NOTICE

Your new machine has a Carbon Monoxide (CO) detection badge; please keep in mind the following important notes about this CO sensor:

- * Once opened, the CO detection badge will expire in 90 days, so write the open date on the badge when installing on your machine.
- * The CO detection badge is individually wrapped and must be unwrapped for detector to function.
- * To apply, simply unwrap the badge, remove the orange backing and apply to the handle assembly of your propane machine, somewhere easily visible to the operator.
- * The CO detection badge is a passive carbon monoxide detector and can detect as little as 100 parts per million (ppm) carbon monoxide gas at an approximate relative humidity range of 33 to 50%. If the humidity is very high it can detect concentrations as low as 20ppm.
- * If CO is present in the area, the circle indicator will change color (from orange-red to red-brown, and then to gray-black as the concentration levels increase).
- * Once the CO detection badge is exposed to fresh air it will return back to orange-red and may be reused.
- * There is no alarm function and requires no power, but must be visible and seen to determine whether CO is present in the area.
- * The CO detection badge will be inactivated and damaged by the presence of halogens (iodine, chlorine, bromine), and ammoniac or nitrous gases.

STORAGE AND HANDLING SAFETY INFORMATION



Always store equipment away from heater rooms, boilers, gas-fired water heaters or any other source of open flame or ignition. The exhaust system will be very hot and takes several minutes to cool, so keep yourself and all materials clear.



Always store equipment away from possible damage by falling objects in warehouse-type areas.



Always store LPG tanks outside. Remove all propane tanks from inside building except during equipment use. Store them in a secure, well ventilated area.



If the engine has been running, allow it to cool for at least 15 minutes before loading the engine-powered equipment onto the transport vehicle. A hot engine and exhaust system can burn you and can ignite some materials.



This propane machine is intended for commercial use.



Safety is a full-time, every day job. Follow all information posted on the machine and the LPG tank. Never allow anyone untrained to operate this machine, and who has not read or cannot understand the given instructions.

PROTECT YOUR WARRANTY!

Read this Owner's Manual carefully and keep it with machine at all times; all questions regarding the care and safety of this equipment:

AZTEC
 215-393-4700 / TOLL FREE 800-331-1423
 parts@aztecproducts.com
 www.aztecproducts.com

BEFORE OPERATION CHECKLIST

For your safety, to ensure compliance with environmental regulations, and to maximize the service life of your equipment, it is very important to take a few minutes before you operate this machine to check its condition. Be sure to take care of any problem you find, or have your service dealer correct it before you operate this machine.

WARNING

Improperly maintaining this machine and its engine, or failure to correct a problem before operation, may cause a malfunction in which you can be seriously hurt or killed. Always perform a pre-operation inspection before each use, and correct any problem.

Before beginning your pre-operation checklist, the machine and engine must be on a level surface, with the engine switch in the OFF position, and the propane tank valve is in the CLOSED position. Always check the following items before you start the engine:

A. READ AND UNDERSTAND ALL SAFETY MESSAGES:

Carefully read and understand the **SAFETY INSTRUCTIONS** on pages 3-9.

B. CHECK THE GENERAL CONDITION OF THE MACHINE:

- 1.) Look around and underneath the machine and engine for signs of oil leaks.
- 2.) Remove any excessive dirt or debris, especially around the muffler and recoil starter.
- 3.) Look for signs of damage.
- 4.) Check that all shields and covers are in place, and all nuts, bolts and screws are tightened.

C. CHECK THE ENGINE:

- 1.) Check the engine oil level and filters. Running the engine with a low oil level can cause engine damage. Your first oil change should be after the first 8 hours of use.
- 2.) Check the air filter element. A dirty air filter element will restrict air flow to the carburetor, reducing engine performance.

D. CHECK THE MAINTENANCE SCHEDULE

All machines are equipped with a multi-function maintenance meter. The functions include the following: hour meter, service alert and tachometer. (See **ENGINE MAINTENANCE METER** instructions on pg 14).

E. CHECK THE ENGINE OIL

Make sure the machine is level when checking the oil. Always take two (2) readings of the dipstick before adding oil. If the oil level is below the full mark, add just enough oil to the engine to bring the oil level up to the full mark. Never over fill. Check for foreign material on the dipstick.

F. CHECK THE PROPANE/LPG TANK AND LINES:

- 1.) Every tank has been pressure and leak tested. However, every time a tank is filled and/or connected to the machine it should be soap tested. All LPG lines must be pressurized and every inch of line and connections must be sprayed. If you find a leak, make the proper repairs before operating the machine.
 - 2.) Never overfill the LPG tank. The LPG tank is designed to hold a maximum of 20 pounds of propane. Make sure to weigh the tank as it is being filled. The gross weight of a full tank should not exceed 48 pounds. If, while operating the machine, you notice frost forming on the LPG lines or the regulator, your tank has been over filled. If you continue to operate the machine in this condition, damage will occur. The excess propane in the tank must be removed before normal operations resume. The bleeding of a propane tank must be done in a safe manner; refer to the **SAFETY INFORMATION** on pgs 3-9. In some cases, the regulator must defrost before restarting the engine.
 - 3.) To connect the high pressure hose to the LPG tank, make sure the couplers are in line and screwed together, hand tight. If this is not done properly, fuel will not pass through to the regulator. Never complete the connection of the tanks to the machine by using a tool; refer to the **SAFETY INFORMATION** on pgs 3-9.
- G.** Once this checklist is complete, restore the machine to an upright, operating position. Then fill water tank before operation if using in wet operation.

STARTING THE ENGINE

- 1.) Once the **BEFORE OPERATION CHECKLIST** on pages 10-11 is completed, adjust the machine handle to comfortable position using pin to secure in place.
- 2.) Adjust the machine handle to comfortable position using pin provided to secure in place.
- 3.) Open the LPG tank valve by turning counter-clockwise.
- 4.) Set the throttle control switch to the SLOW position.
- 5.) Push the "START" button until engine starts. Starter should not be engaged for more than 10 seconds at a time. If hard starting is a problem, carefully review **BEFORE OPERATION CHECKLIST** pages 10-11. As soon as the engine starts, immediately move throttle cable into desired engine speed.
- 6.) Begin operation of machine.

STOPPING THE ENGINE

To stop the engine in an emergency, simply move the control lever to the OFF position. Under normal conditions, use the following procedure:

Move the control lever to the OFF position. The control lever shown to the right is connected to a throttle cable.

- 1.) Turn the key switch to the OFF position.
- 2.) Turn the propane valve lever to the CLOSED position by turning the valve clockwise.

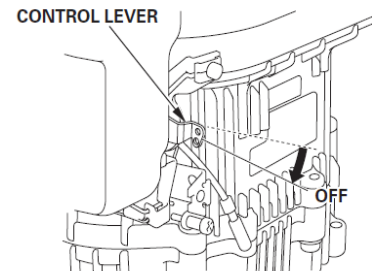

CONTROL LEVER

The control lever operates the engine switch and throttle.

- OFF** ----- Stop the machine by switching off the ignition system. All other control lever positions leave the ignition system switched ON.
- MIN.** ----- For running the engine at idle speed.
- MAX.** ----- For restarting a warm engine, and for running the engine at maximum speed.

The control lever shown here will be connected to a throttle cable.

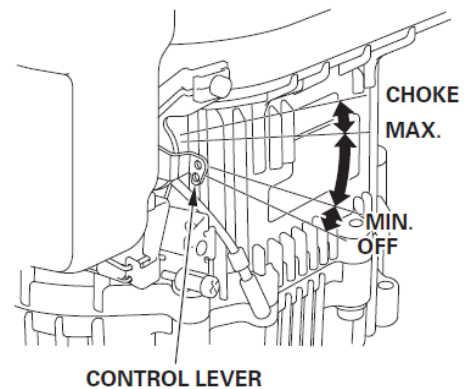

SETTING ENGINE SPEED

Position the throttle cable to the desired engine speed.

OPERATION

This multi-purpose machine is designed to deep scrub/strip, hone, polish and burnish floors in preparation for top coat or restoring of tile, smooth concrete, terrazzo or close fitted tile. No other application of this equipment should be attempted nor is recommended.

Contact Aztec (parts@aztecproducts.com) for any additional application questions.

First, refer to the **SAFETY INFORMATION** on pages 3-9, and complete the **BEFORE OPERATION CHECKLIST** on page 10-11.

WARNING

Never tilt back machine while engine is running. Objects may fly out from underside of machine and damage can occur to the machine, furniture, buildings and/or personal injury.

NOTICE

Provide and use ear protection during operation.

NOTICE

All machines are equipped with tamper proof fuel systems. If a fuel problem exists, contact an authorized service center.

NOTICE

All machines are equipped with a multi-function maintenance meter. The functions include the following: hours, service alert and tachometer; see **ENGINE MAINTENANCE METER** instructions on page 14.

NOTICE

Engine speed not to exceed 3400 RPM. High and low idle speeds may vary depending on the equipment on which the engine is used. Refer to the equipment specifications.

NOTICE

This machine is not suitable for picking up hazardous dust.

NOTICE

Do not use this machine on surfaces with a gradient exceeding 2%.

NOTICE

This machine is supplied with a centrifugal clutch. When the engine RPM is lower than 1800 RPM, the clutch will disengage; brushes/pads will stop.

ENGINE MAINTENANCE METER

This multi-function meter acts as a preventive maintenance tool, which benefits you with increased fuel economy, less down-time and longer engine life.

The meter displays are:

- **Hour Meter:** Displays total run hours when machine is off.
- **Tachometer:** Indicates engine RPM during operation.
- **Service Alert:** The display flashes to alert you to lube and change the oil at 25 hour intervals. After the service is complete, the meter can be reset by pushing the reset button on the face of the meter. Therefore, it is recommended that a separate maintenance log be kept to track of oil changes.

TRANSPORTING THE MACHINE

CAUTION

The Refresher must be secured on a level surface when transporting in a vehicle. Once the machine is loaded into the transport vehicle, remove and store the Transport Wheel on the top deck of the machine. Secure the machine in the vehicle so it cannot move or bounce during transporting; damage may occur to the machine and/or the vehicle and surrounding objects.

First, refer to the **SAFETY INFORMATION** on pages 3-9. The machine must be on a level surface, with the engine switch in the OFF position, and the propane tank valve in the CLOSED position.

Remove the propane tank from the machine, or disconnect the connection and securely fasten tank to machine. Adjust handle of machine to comfortable position to tilt back; secure handle in place with pin provided.

To tilt back the machine, place one foot on the propane tank base bar, one hand on the handle base, and one hand on the "T" handle. Pull back and down from the handle base, and push down with your foot, using the "T" handle only to control lateral motion.

Once secured in a tilted back position, insert transport wheel and secure with pin provided. Push machine forward, to desired location, unless loading machine up on a ramp into a vehicle. When loading up a ramp into a vehicle, the machine should be pulled back rather than pushed forward, to prevent tipping over.

INSTALLING PAD DRIVERS, DIAMOND DRIVERS, STRIP BRUSHES

First, refer to the **SAFETY INFORMATION** on pages 3-9. Install fresh pads/brushes/resins/hybrids before every job.

CAUTION

Do not remove tape from strip brushes. Removing the tape from the strip brush reduces the brush life and effectiveness.

To remove pad drivers, diamond drivers or strip brushes, tilt machine back and secure in place. To tilt back the machine safely, refer to **TRANSPORTING THE MACHINE** above. To remove Velcro® diamond pucks, pull apart from inside edge of drive pad, NOT from outside edge.

NOTICE

Do not pull Velcro® diamond pucks from outside edge of drive plate, to avoid damage to adhesive surface on the outer surface. Remove only from the center out, towards the outer edge.

NOTICE

Dispose of used pads, brushes, hybrids and diamonds responsibly. Once the machine is secured in the tilted back position, rotate the drivers approximately 1/8 turn clockwise to release from the spring clip, and remove.

To install pad drivers, diamond drivers or strip brushes, align the three lugs on top of the driver with the holes on the drive plate; rotate driver counter-clockwise until driver clicks and locks into spring clip securely.

Remove old pads and center the new pads onto each pad driver, one at a time.

NOTICE

Never “flip” a pad. Keep the same side down throughout the life of the pad. Even after a pad is cleaned, you can tell the down side by the centering ring indentation. This practice will increase the pad life and help maintain a properly functioning pad driver.

MACHINE CLEAN UP

Refer to the **SAFETY INFORMATION** on pages 3-9. Once the job is complete for the day/night, clean up is required. The manufacturer's and engine warranty will be voided if the equipment is not properly maintained. Clean the entire machine after each use:

- A. Turn the propane tank valve clockwise to CLOSED position and turn the engine key to OFF position.
- B. Empty excess water from water tank.
- C. Refer to **TRANSPORTING THE MACHINE** on page 14 to properly tilt back and secure machine.
- D. Check the machine for possible loose nuts and bolts; tighten and secure as needed.
- E. Rinse the machine with water between the top of brushes and the brush plates. Do not spray water into brush drive (above large main plate).
- F. Rinse around splash skirt and body of machine.
- G. Return the machine to leveled operating position, then start engine and run machine for 2-3 minutes to expel any excess water.
- H. Return machine to upright position unless transporting to storage area; refer to **TRANSPORTING THE MACHINE** on page 14.

STORING THE MACHINE AND PROPANE TANKS

Once the job is complete for the day/night, remove the propane tank from the machine and store the tank in a well ventilated approved area. Store your machine in a safe and secure area. Refer to the **SAFETY INFORMATION** on pages 3-9.

TROUBLESHOOTING THE ELECTRICAL SYSTEM

WARNING

Always wear a face shield, safety glasses and protective clothing when working around a battery. The gases can be explosive and the acid is highly corrosive to metals, cloth and ALL HUMAN TISSUE (skin, eyes, etc.).

NOTICE

Safety first. Contact an authorized service center as needed.

- Check all wire connections for obvious problems. Remove propane tank, then remove battery box cover. Check all connections visibly and physically. If any “loose”, damaged or unconnected wires are noticed, replace or repair as needed.
- Check the battery posts and wires. If the battery post(s) are corroded, remove the wires and clean posts and wires. Applying some axle grease on the posts of the battery after they are cleaned will slow down the battery corrosion process. If nothing obvious is noted, a more detailed investigation is warranted. Before any such troubleshooting begins, the following things should be done:
 - Replace propane tank with one from a machine that runs.
 - Charge the battery or provide an absolute source of 12 volt DC power capable of 50 amperes total output. Jumper cables from a car or truck battery will suffice. Use a 12-volt test light.
- If the problem appears to be in the electrical control equipment, disconnect the starter from the system so as to check the system without spinning the engine.
- Battery rundown is a common problem. An engine key left in the ON position when engine is turned OFF will result in battery running down.

TROUBLESHOOTING MAIN DRIVE BELT

NOTICE

Safety first. Contact an authorized service center as needed.

If the engine runs but the drive unit will not engage, this is usually related to the main drive brush belt or belt tension spring. Without removing the drive unit you can check and fix the following:

- 1) Remove the four 3/8" bolts holding the belt cover to the body. Remove the (1) 3/8" bolt holding the muffler bracket to the belt cover. Check if belt tension spring is attached to the idler spring mount bolt on the body.
- 2) Check to see if belts have come off of input pulley or centrifugal clutch. If so, install belts back on the pulley. Note: If belts come off again they are probably worn or stretched and need replacement.
- 3) To replace engine drive belts:
 - a. Loosen the (3) bolts on the right hand side of the upper deck approximately 4 to 5 turns. Be sure at least half of the bolt threads remain engaged. Place machine in the tilt-back position. Remove old or worn belts and replace them with the new ones.
 - b. Remove one end of the tension spring to aid in installation of new belts. Check for wear on the springs and their catches.
- 4) Re-attach tension spring to mount bolt and tighten (3) 1/2" bolts. Slide the belt cover into place and start (4) 3/8" bolts into belt cover (hand tighten only). Start (1) 3/8" bolt into muffler bracket and belt cover, then tighten all (5) 3/8" bolts.
- 5) To change the brush drive belt: Remove three (3) bolts on the right hand side of upper deck (use a 3/4" wrench). Slowly raise front of machine off the floor. Remove Input Boom Pulley and Boom Arm from Brush Drive by using the two 3/4" wrenches—sliding them into the slots in the boom pulley shaft to unscrew the pulley from the shaft. Remove six (6) bolts from bottom side of Brush Drive and split Brush Drive Top Pan and Brush Drive Plate. Remove worn belt and replace. It is a good idea at this time to check the Tension Spring, bearings and idler for damage and replace them if necessary.

NOTES

ENGINE OIL AND MAINTENANCE

⚠ WARNING

Hot engine oil can cause severe burns. Allow engine temperature to drop from hot to warm level before attempting to remove oil filter.

⚠ WARNING

Check the engine oil daily before starting the engine, otherwise shortage of the engine oil may cause serious damage to the engine such as seizure.

⚠ WARNING

Engine oil is a toxic substance. Dispose of used oil properly. Contact local authorities for approved disposal methods or possible recycling.

Refer to the **SAFETY INFORMATION** on pages 3-9. Also refer to the **BEFORE OPERATION CHECKLIST** on pages 10-11 before operating this machine. Then carefully follow these guidelines.

A.) RECOMMENDED OIL

The following engine oils are recommended: **API Service Classification: SF, SG, SH, or SJ.**

B.) CHECK THE OIL

- 1) To check the oil, the engine should be turned OFF, and the machine should be on a level surface.
- 2) Clean the area around the oil gauge before removing it.
- 3) Remove the oil gauge and wipe it with a clean cloth.
- 4) Pour the oil slowly to "FULL" mark on the oil gauge.
- 5) Insert the oil gauge into the tube WITHOUT SCREWING IT IN.
- 6) Remove the oil gauge to check the oil level. The oil level should be between "ADD" and "FULL" marks. Do not overfill.
- 7) Install and tighten the oil gauge.

C.) OIL VISCOSITY

Choose the viscosity according to the temperature as follows:

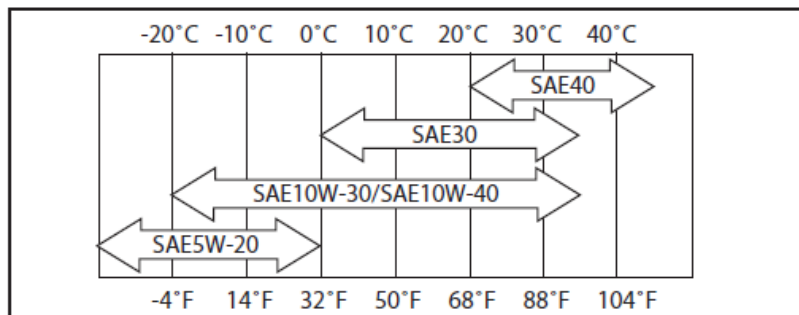

NOTICE

Using multi-grade oils (5W-20, 10W-30, and 10W-40) will increase oil consumption. Check oil level more frequently when using them.

D.) ENGINE OIL CAPACITY

For the Kawasaki FS481V engine, 1.7 L (1.8 US qt.) when oil filter is removed

E.) OIL CHANGES

Change oil after first 8 hours of operation. Thereafter change oil every 50 hours.

- Run the engine to warm oil.
- Be sure the engine (equipment) is level.
- Stop the engine.
- Open the oil drain valve and drain the oil into suitable container while engine is warm.

F.) OIL DRAIN PLUG

- Close the oil drain valve.
- Remove oil gauge and refill with fresh oil (See **RECOMMENDED OIL** on pages 18-20).
- Check the oil level (refer to the **BEFORE OPERATION CHECKLIST** on pages 10-11 for **OIL LEVEL CHECK**).

G.) OIL FILTER CHANGE

Change the oil filter every 100 hours of operation.

CAUTION

Before removing the oil filter, place a suitable pan under filter connection.

- Drain engine oil into a suitable container.
- Rotate the oil filter (A) counterclockwise to remove it.
- Coat a film of clean engine oil on seal of new filter.
- Install new filter rotating it clockwise until seal contacts mounting surface (B). Then rotate filter 3/4 turn more by hand.
- Supply engine oil as specified.
- Run the engine for about 3 minutes, stop engine, and check oil leakage around the filter.
- Add oil to compensate for oil level drop due to oil filter capacity (refer to the **BEFORE OPERATION CHECKLIST** on page 10-11 for **OIL LEVEL CHECK**).

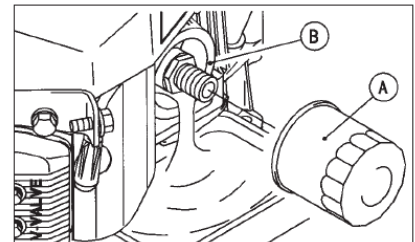

NOTICE

A maintenance record must be kept, indicating all dates of service, hours on engine at time of service, and service performed in order to maintain manufacturer's warranty coverage. Perfect record keeping does not guarantee warranty coverage if the damage to the machine is non-warrantable. See warranty coverage policy details at the end of this Owner's Manual. The maintenance record must be kept with the machine and transferred to the new owner if resold.

NOTICE

The manufacturer's warranty will be voided if the machine is not maintained in accordance with this manual's recommended maintenance instructions and the engine manufacturer's recommended maintenance procedures. Failure to do so may cause damage to the machine, equipment, furniture, buildings and/or personal injury.

PUREPOWERLPG™ ENGINE MAINTENANCE SCHEDULE

MAINTENANCE	INTERVAL						
	<i>Daily</i>	<i>First 8 hr.</i>	<i>Every 25 Hr.</i>	<i>Every 50 hr.</i>	<i>Every 100 hr.</i>	<i>Every 200 hr.</i>	<i>Every 300 hr.</i>
<i>Check and add engine oil</i>	•						
<i>Check for loose or lost nuts and screws</i>	•						
<i>Check for fuel and oil leakage</i>	•						
<i>Check battery electrolyte level</i>	•						
<i>Check or clean air intake screen</i>	•						
<i>Clean air cleaner foam element</i>			•				
<i>Clean air cleaner paper element</i>				•			
<i>Clean dust and dirt from cylinder and cylinder head fins</i>					•		
<i>Tighten nuts and screws</i>					•		
<i>Change engine oil</i>		•		•			
<i>Clean and gap spark plugs</i>					•		
<i>Change oil filter</i>					•		
<i>Replace air cleaner paper element</i>					•		
<i>Clean combustion chambers</i>							•
<i>Clean and adjust valve clearance</i>				•*			•
<i>Clean and lap valve seating surface</i>							•

*After the 1st 50 hours

ENGINE TROUBLESHOOTING

COMMON PROBLEMS & PROBABLE CAUSES	SOLUTIONS
Engine cranks but will not start: Fuel cylinder is empty Shutoff valve is closed Clogged, obstructed, kinked or cut fuel or vacuum line Spark plug lead disconnected Faulty ignition coil Faulty kill switch Faulty regulator	Refill cylinder Open valve Remove obstruction or replace line Connect lead to spark plug Replace ignition coil Replace switch Replace regulator
Engine starts hard: Faulty choke or throttle settings Clogged, obstructed, kinked or cut fuel or vacuum line Faulty regulator Low compression	Set controls to correct position Remove obstruction or replace line Replace regulator Have engine serviced by a trained technician
Engine will not crank: Battery is discharged Loose or faulty connections or wires Faulty ignition key switch or starter control switch	Charge or replace battery Tighten, repair or replace wires Repair or replace switch(es)
Engine overheats: Incorrect fuel settings Air intake filter screen or cooling fins clogged Low oil level	Have engine serviced by a trained technician Clean and clear debris or replace filter Check and add oil
Exhaust emissions or propane odor: Carburetor or regulator setting incorrect Dirty or clogged air filter Loose fittings, clamps or hoses cracked, hoses cut or leaking	Have engine serviced by a trained technician Replace air filter Tighten or seal; check with soap and water solution, if bubbles appear, part is still leaking; replace

ENGINE BATTERY START WIRING DIAGRAM

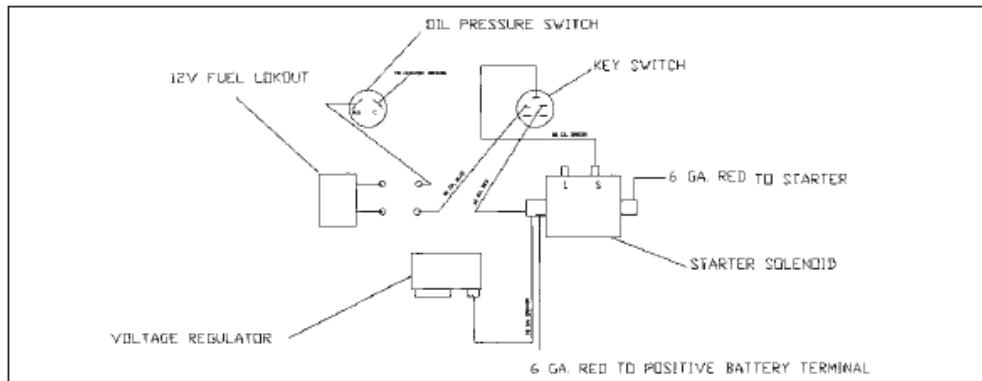

ENGINE TUNE-UP SPECIFICATIONS

ITEM	SPECIFICATIONS
Ignition Timing	Non-adjustable
Spark Plugs (gap)	NGK BPR4ES (.028 in)
Low Idle Speed	1500 RPM
High Idle Speed	3400 RPM
Valve Clearance	IN: 0.10-0.15 mm (0.004-0.006 in) EX: 0.10-0.15 mm (0.004-0.006 in)

AZTEC REFRESHER QUICK START GUIDE

<p>1.) Read, understand and observe all important SAFETY INSTRUCTIONS before operating the machine (see pgs 3-9).</p> <p>2.) Complete the BEFORE OPERATION CHECKLIST on pgs 10-11.</p> <p>3.) Make sure the machine is properly maintained prior to use (see maintenance records and pgs 17-20).</p> <p>4.) Make sure the LPG tank (A) is filled, connected and checked for leaks (see pg 11).</p>	<p>5.) Open the LPG tank by turning the knob (B) counter-clockwise.</p> <p>6.) Set throttle lever (C) to idle/SLOW position</p> <p>7.) Turn key (D) to start [I] position</p> <p>8.) Move throttle lever (C) toward FAST position. If motor fails to start, return to Step 5 above.</p> <p>9.) Set throttle lever (C) to desired operating speed and follow the moving machine (straight ahead) at moderate walking pace (keep moving).</p>
--	---

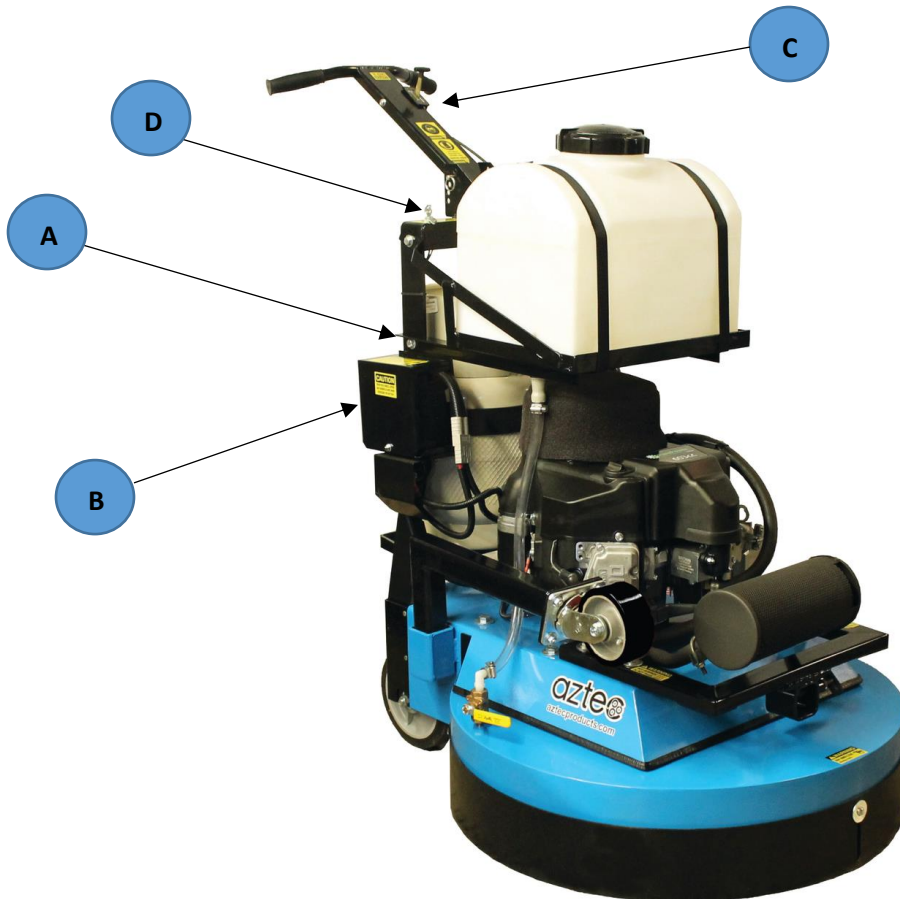

REFRESHER 30" WARNING LABEL LOCATIONS

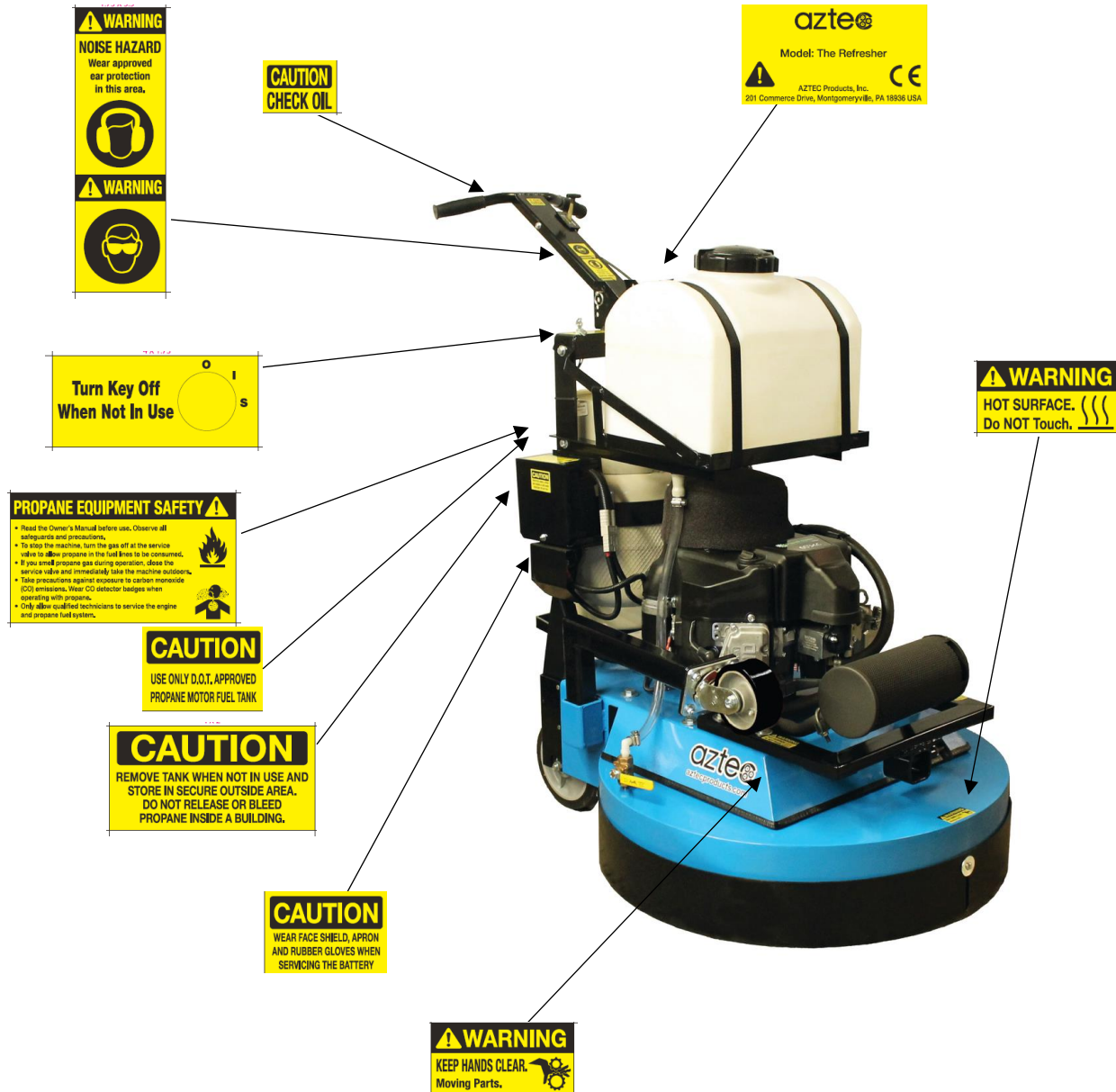

Order Aztec Approved replacement parts
for your Aztec floor machine here:

aztec.parts

Or email us for parts not yet on our parts website:

parts@aztecproducts.com

The Preventative Maintenance Kit for the FS481 engine, Part # [309-603-PH](#) includes the following parts:



PART #	DESCRIPTION	QTY IN KIT
309-11013-7046	Pre Filter (Foam Hat)	1
309-11013-7049	Air Filter (Paper Element)	1
309-49065-7007	Oil Filter	1
309-92070-7004	Spark Plugs (NGK BPR4ES)	2
119-Oil	10W30 Quart Oil	2
186-271964	Debris Filter (Foam Hat)	1

REGULATOR, DRIVE BELT, PROPANE TANK DIAGRAM & PARTS

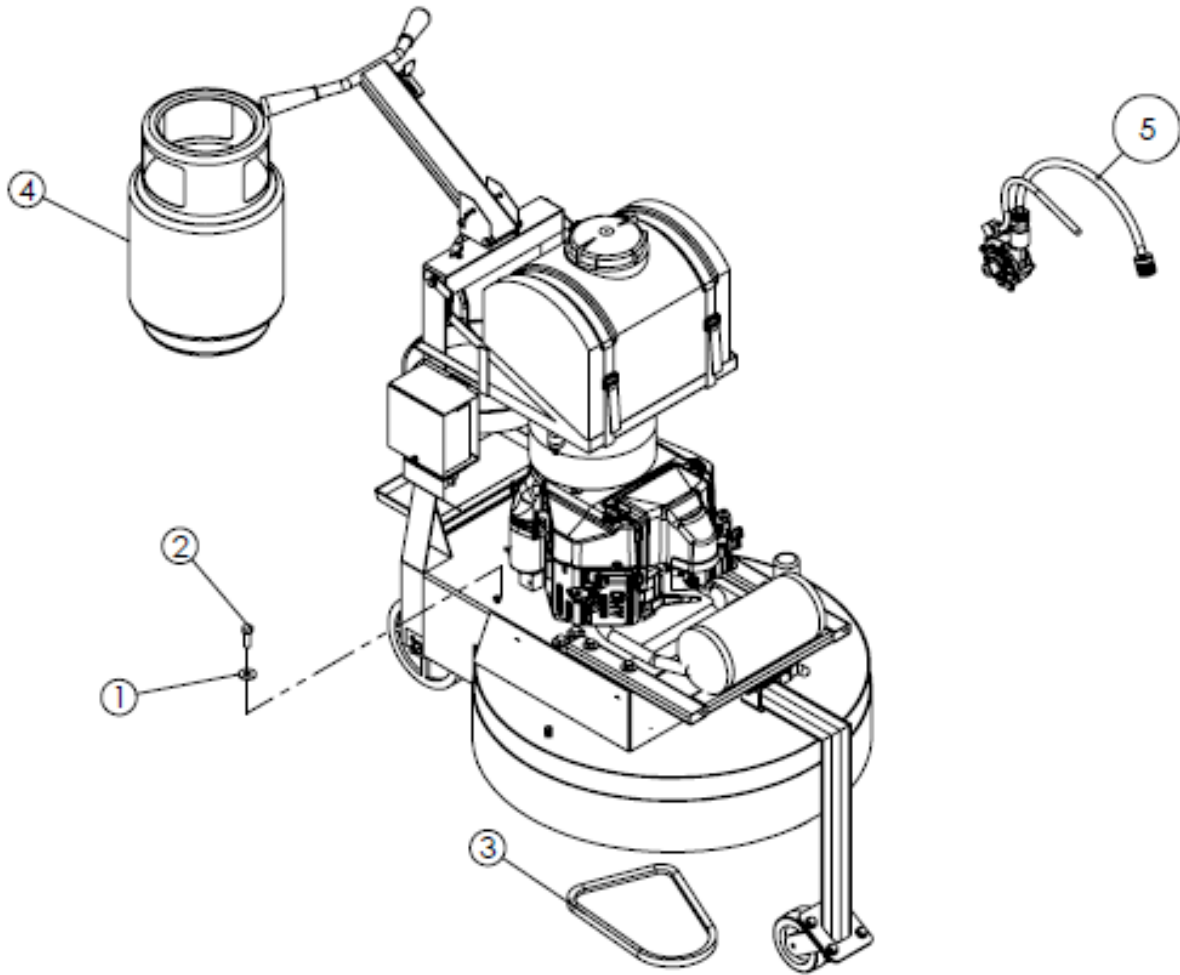

REF	DESCRIPTION	PART #	QTY
1	½ USS FLAT WASHER	164-20159	3
2	HEX CAP SCREW ½-13 X 1 1/2	164-10215	3
3	ENGINE BELT 38"	113-L538	1
4	PROPANE TANK	293-20#STLMF	1
5	REGULATOR ASSEMBLY FOR REFRESHER	152-1	1

REFRESHER DECK ASSEMBLY DIAGRAM

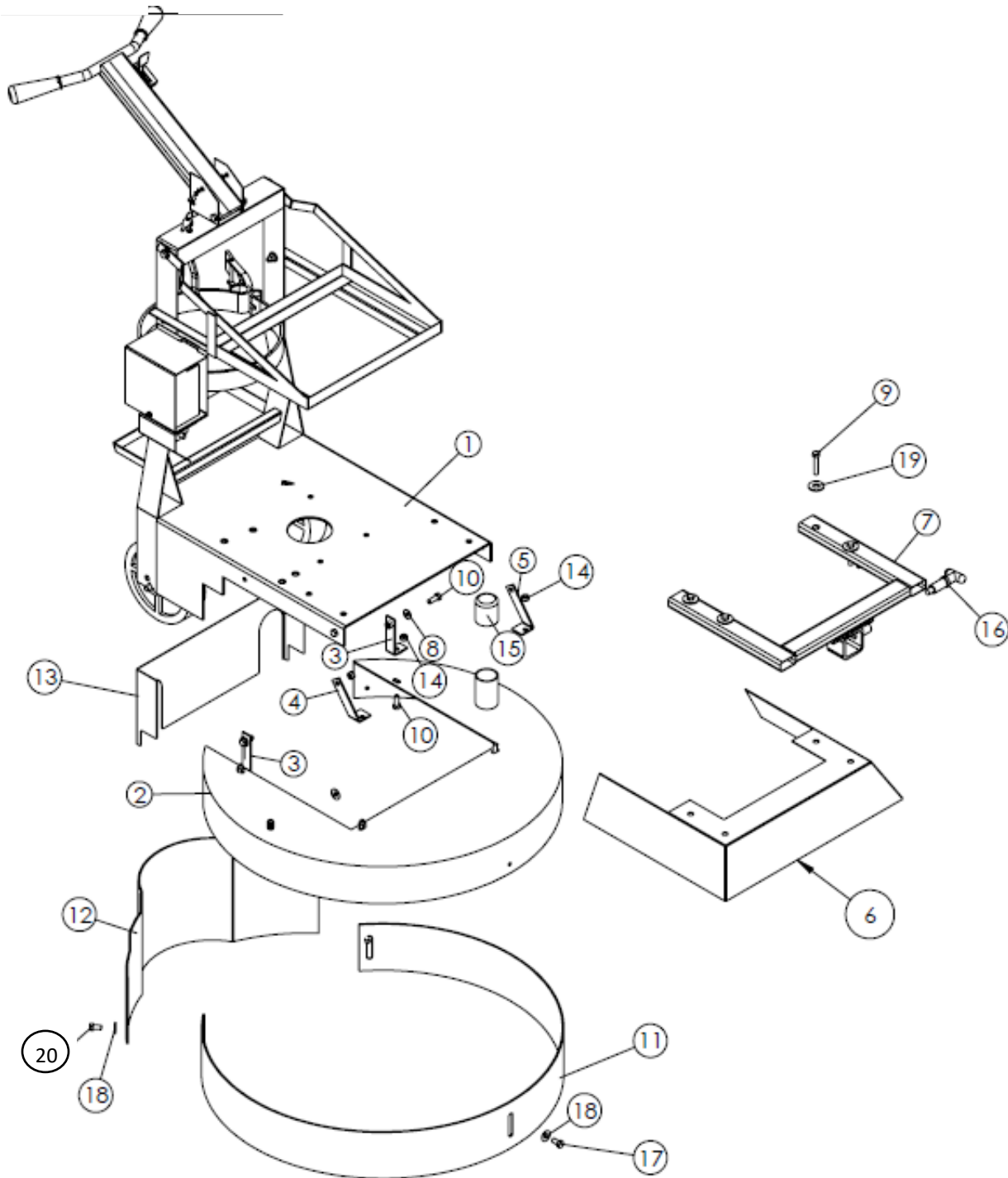

REFRESHER DECK ASSEMBLY PARTS

REF	DESCRIPTION	PART #	QTY
1	BODY FRAME	370-042-01	1
2	DRIVE COVER	370-042-02	1
3	REAR BODY BRACKET	283-010-07	2
4	FRONT RIGHT BODY BRACKET	283-010-06	1
5	FRONT LEFT BODY BRACKET	283-010-05	1
6	BELT COVER	370-042-03	1
7	TRANSPORT WHEEL BODY BRACKET	370-042-05	1
8	5/16 USS FLAT WASHER	164-20156	2
9	HEX CAP SCREW 3/8-16 X 2	164-10123	4
10	HEX CAP SCREW 3/8-16 X 1	164-10115	8
11	DUST SKIRT ASSEMBLY	042-971SA	1
12	REAR SPLASH BELTING (SOLD BY FOOT)	042-971RS	2.5 FT
13	KICK PLATE	283-010-04	1
14	HEX NUT 3/8-16	164-22004	8
15	VACUUM PORT CAP	040-3015	1
16	T-KNOB QUICK RELEASE PIN	625-09300088	1
	SKIRT HARDWARE:		
17	5/16-18 X 3/4 SLOT ROUND HEAD MS	164-10061	1
18	5/16 FENDER WASHER	164-20207	3
19	½ USS FLAT WASHER	164-20159	5
20	5/16-18X3/4 HEX	164-10059	4
NOT PICTURED	SKIRT – RUBBER OVERLAY	042-971S2	1
	VELCRO HOOK (FOR SKIRT- SOLD BY FOOT)	042-972H	7 FT

HANDLE ASSEMBLY DIAGRAM

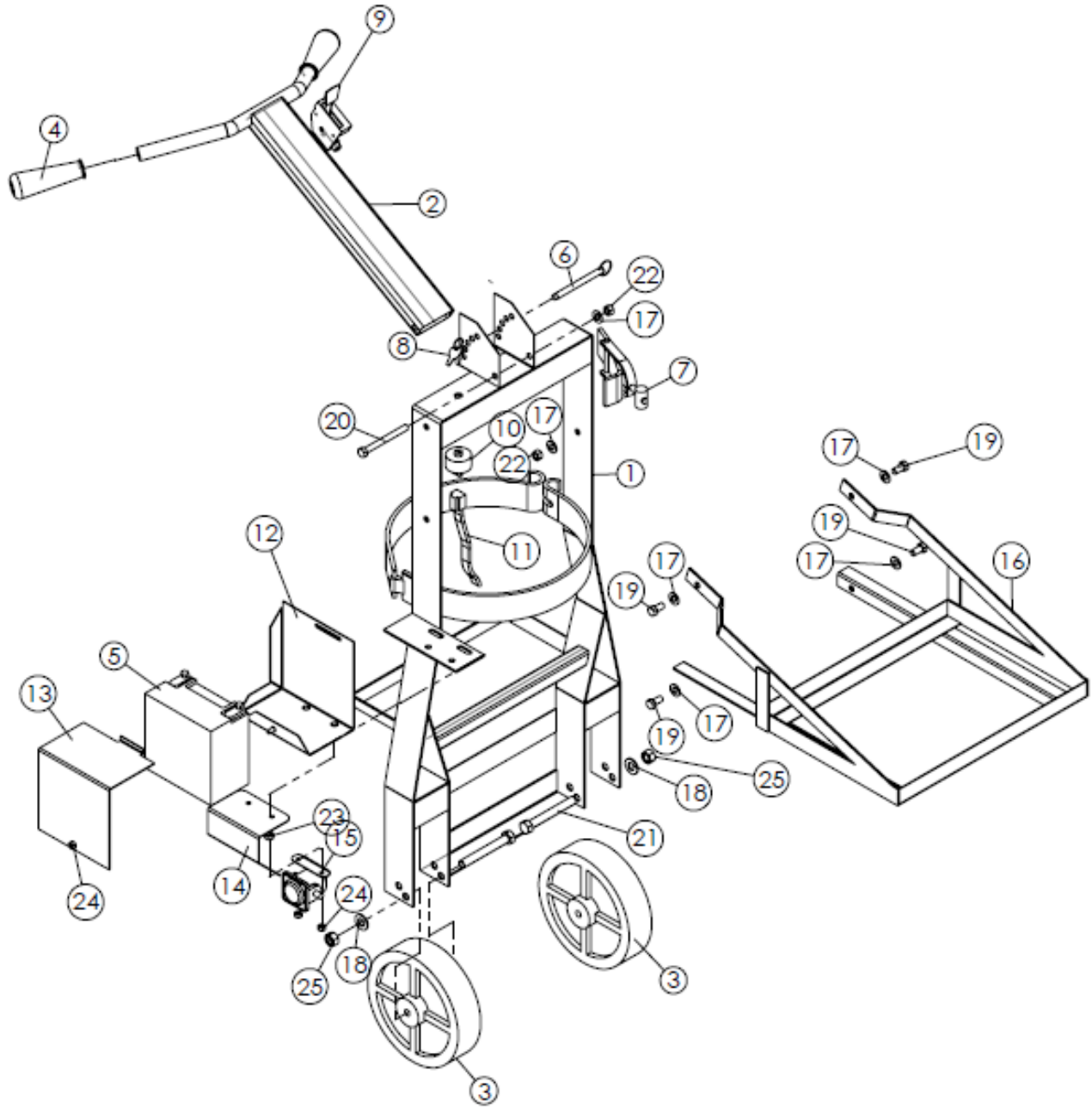

HANDLE ASSEMBLY PARTS

REF	DESCRIPTION	PART #	QTY
1	HANDLE FRAME	370-010-971CCH	1
2	T-HANDLE	370-27-25	1
3	8" WHEEL - SOLID	156-042	2
4	HANDLE GRIP	224-987319	2
5	BATTERY 12V	276-GTX14	1
6	RELEASE PIN – SPRING LOAD	625-98404A395	1
7	TOGGLE & NUT	284-TB2-60	1
8	REPLACEMENT KEY	196-3112932	1
9	THROTTLE CABLE	212-1	1
10	KEY SWITCH	312-308-0385	1
11	WIRE HARNESS	011-762WHK	1
12	BATTERY BOX BOTTOM COVER	283-11-2127B	1
13	BATTERY BOX TOP COVER	283-11-2127T	1
14	SOLENOID GUARD	283-11-SC	1
15	STARTER SOLENOID	296-SS581	1
16	SOLUTION TANK BRACKET	370-010-04	1
17	5/16 USS FLAT WASHER	164-20156	7
18	SPANNER BUSHING	156-ZF-0812-39	2
19	HEX CAP SCREW 3/8-16 X 1	164-10115	4
20	HEX CAP SCREW 3/8-16 X 3 3/4	164-37C375HCS5Z	1
21	AXLE NUT & BOLT	156-ALBZJ085408	2
22	3/8-16 STOVER 10K-NUT	164-22834	3
23	5/16-18 HEX NUT	164-22002	2
24	FLANGE BUT 1/4-20	164-14FN	3

SOLUTION TANK ASSEMBLY DIAGRAM & PARTS

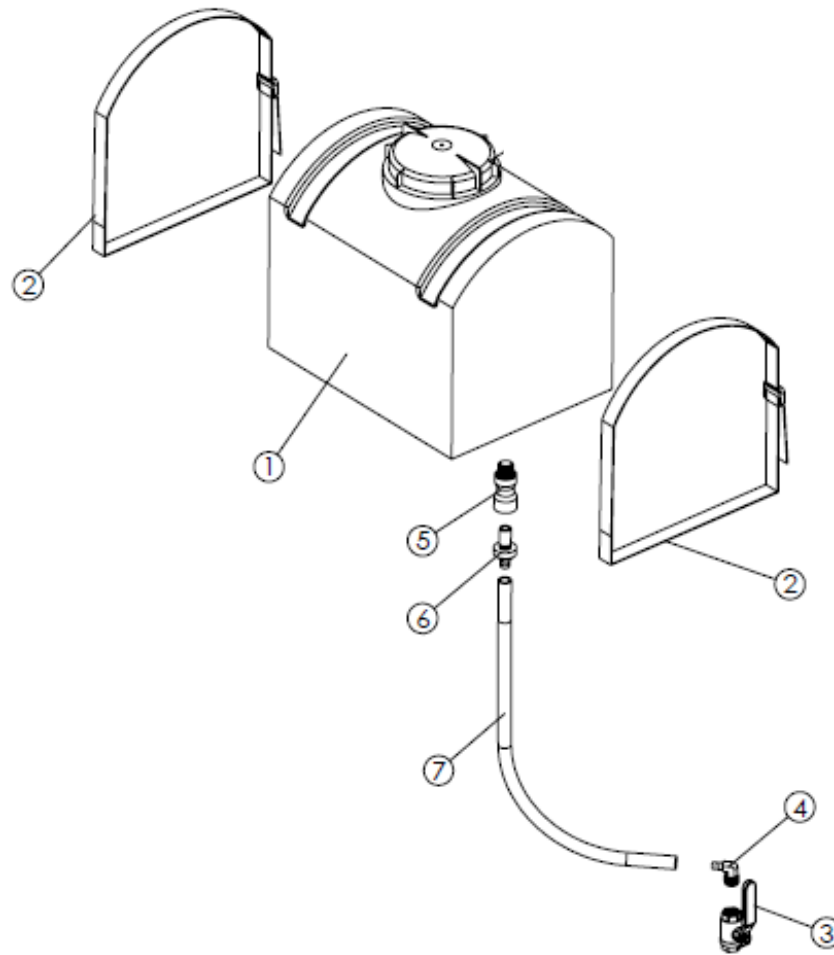

REF	DESCRIPTION	PART #	QTY
1	8 GALLON SOLUTION TANK WITH LID	010-971MGT	1
2	SOLUTION TANK STRAP	010-MG-STRAP	2
3	BALL VALVE 1/2"	030-20-117	1
4	ELBOW 1/2 NPT/BARB	166-EL1412	1
5	QUICK COUPLING FEMALE	040-3025	1
6	QUICK COUPLING MALE	040-3020	1
7	FLEXIBLE TUBING 20"	216-NYC0812	1

DRIVE ASSEMBLY DIAGRAM & PARTS

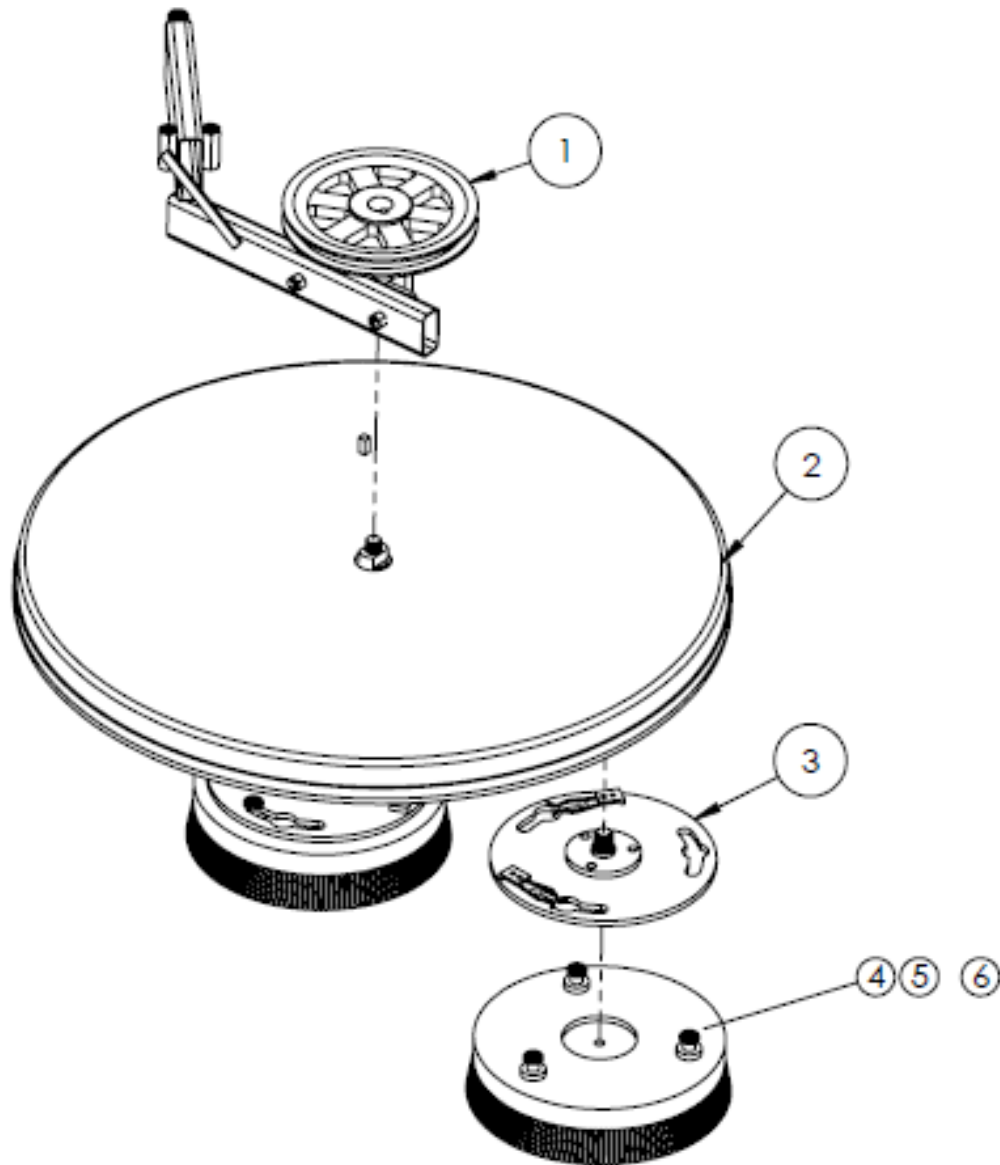

REF	DESCRIPTION	PART #	QTY
1	INPUT PULLEY ASSEMBLY*	042-962S1	1
2	DRIVE ASSEMBLY	042-953B	1
3	DRIVE PLATE ASSEMBLY	042-150	3
4	STRIP BRUSH ASSEMBLY	042-1-S	3
5	PAD DRIVER ASSEMBLY	042-1-P	3
6	DIAMOND DRIVER ASSEMBLY	042-1-D	3

*Input Pulley Assembly (part # 042-962S1) includes Ref #s 2, 6, 7, 8 & 9

INPUT PULLEY ASSEMBLY DIAGRAM & PARTS

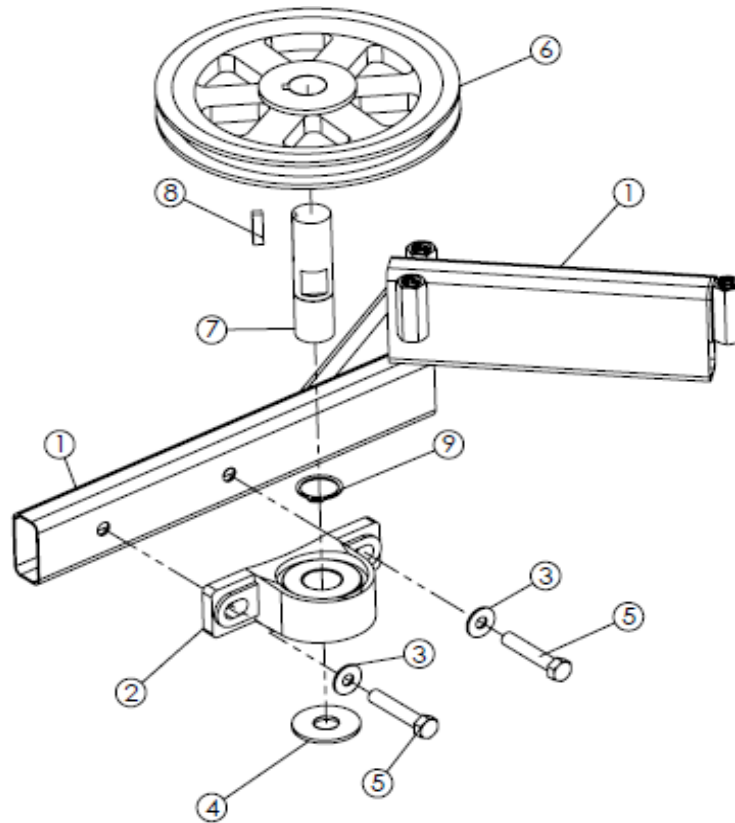

REF	DESCRIPTION	PART #	QTY
1	SUPPORT BOOM ARM	010-962BPF	1
2	PILLOW BLOCK BEARING	239-NP-16C	1
3	5/16 USS FLAT WASHER	164-20156	2
4	BOOM WASHER	164-58114F	1
5	HEX CAP SCREW 3/8-16 X 2	164-10123	2
6	PULLEY, MB 78 X 1	172-MB78*1	1
7	INPUT PULLEY SHAFT	107-3843	1
8	1/4" KEY	199-NHNT-SE UND	1
9	SNAP RING CENTER SHAFT	164-5100-100	1
10	INPUT PULLEY ASSEMBLY*	042-962S1	1

*Input Pulley Assembly (part # 042-962S1) includes Ref #s 2, 6, 7, 8 & 9

REFRESHER DRIVE ASSEMBLY DIAGRAM

NOTE: DIAGRAM IS FOR SERIAL #0420001058 AND UP. FOR LOWER SERIAL NUMBERS PLEASE CONTACT AZTEC: PARTS@AZTECPRODUCTS.COM

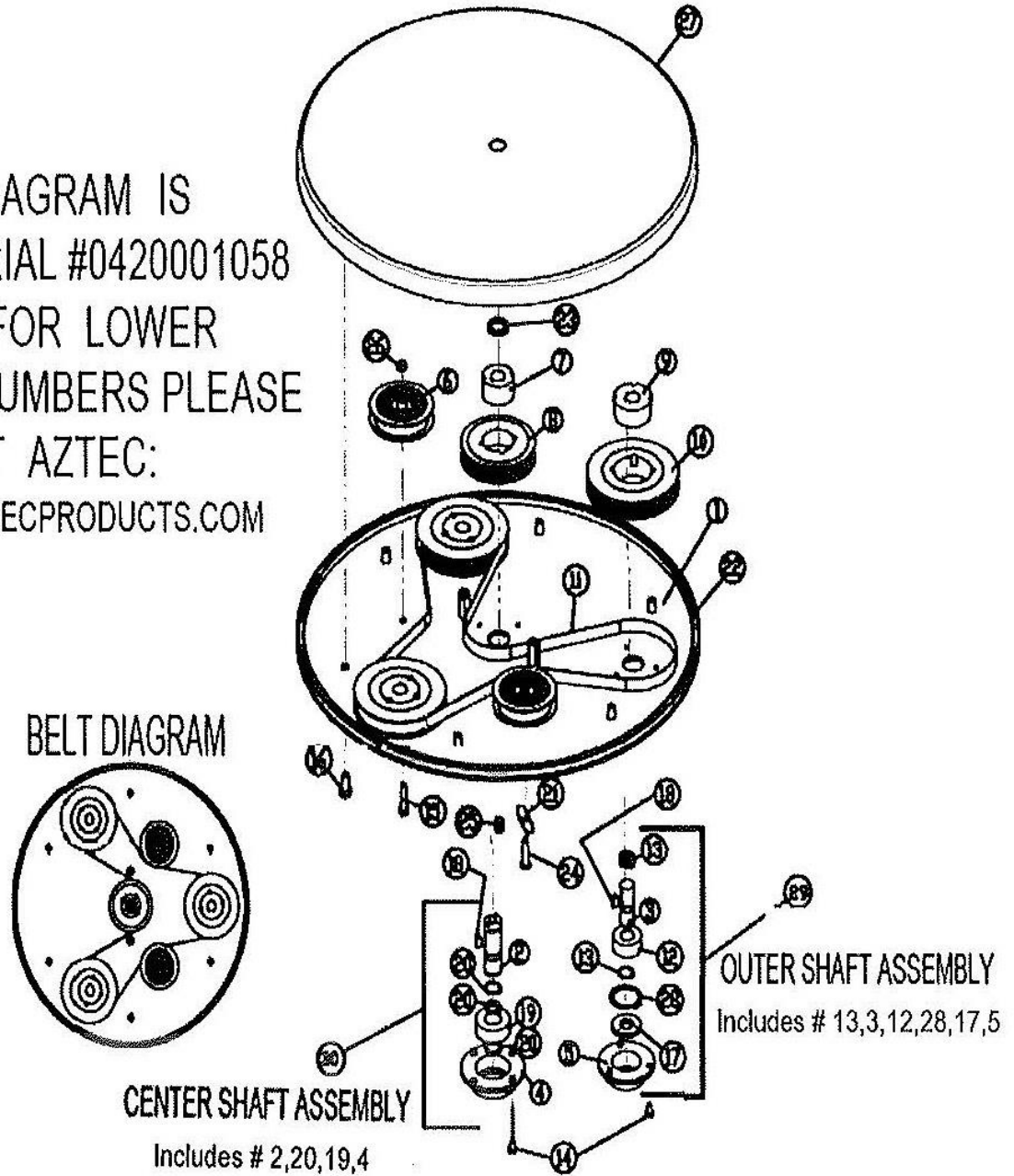

REFRESHER DRIVE ASSEMBLY PARTS

REF	DESCRIPTION	PART #	QTY
1	POWDERCOATED STEEL PLATE	370-042-50	1
2	CENTER SHAFT	042-70	1
3	OUTER SHAFT	042-60	3
4	CENTER CAPTURE	042-20	1
5	OUTER CAPTURE	042-10	3
6	FLAT IDLER PULLEY	042-210	2
7	CENTER TAPER LOCK BUSHING 30mm	042-110-1	1
8	CENTER SPROCKET	042-110	1
9	OUTER TAPER LOCK BUSHING 25mm	042-120-1	3
10	OUTER SPROCKET	042-120	3
11	TWIN POWER SYNC BELT	042-130	1
12	OUTPUT SHAFT BEARING	239-5205CZZ-W64	3
13	OUTER SHAFT SNAP RING	164-5100-100	9
14	HEX CAP SCREW 5/16-18 X ½	164-31C50HCS3	13
15	HEX CAP SCREW 3/8-16 X 2	164-10123	1
16	HEX CAP SCREW 1/2-13 X 1	164-10211	6
17	OUTER SHAFT SEAL	239-00610651	3
18	8MM x 18MM SQUARE END KEY	199-042	4
19	CENTER SHAFT BEARING	239-5206CZZ-W64	1
20	CENTER SHAFT SNAP RING	164-5100-118	3
21	SLOT SHIELD DUST GUARD	042-140	1
22	COVER SEAL	179-1645SB3-338	7.5'
23	V-RING SEAL	042-230	1
24	CARRIAGE BOLT 3/8-16 X 2	164-37C200BCGZ	1
25	STUD 5/8-11 X 1½	164-5/8-11*1.5	1
26	HEX NUT 3/8-16	164-22004	2
27	DRIVE BELT TOP COVER	370-042-962MS	1
28	OUTER CAPTURE SNAP RING	164-DIN472-052	3
29	OUTER SHAFT ASSEMBLY	042-A-2	3
30	CENTER SHAFT ASSEMBLY	042-A-1	1

TENSIONER ASSEMBLY DIAGRAM & PARTS

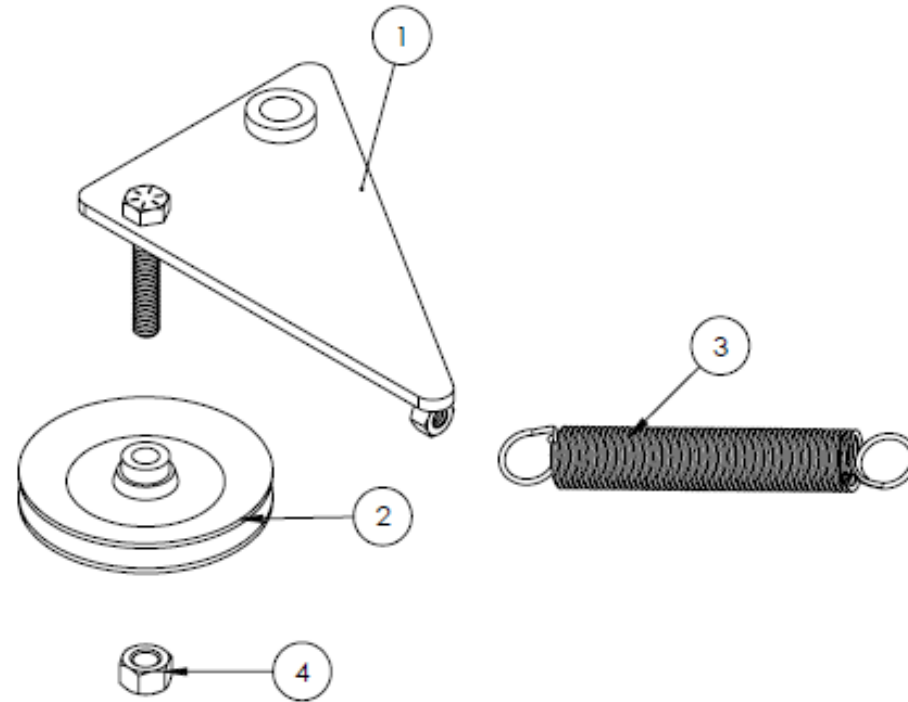

REF	DESCRIPTION	PART #	QTY
1	BELT TENSIONER	042-962i	1
2	V-IDLER PULLEY	188-V42B	1
3	TENSIONER RETURN SPRING	173-042	1
4	HEX NUT 3/6-16	164-22004	1

TRANSPORT WHEEL ASSEMBLY DIAGRAM & PARTS

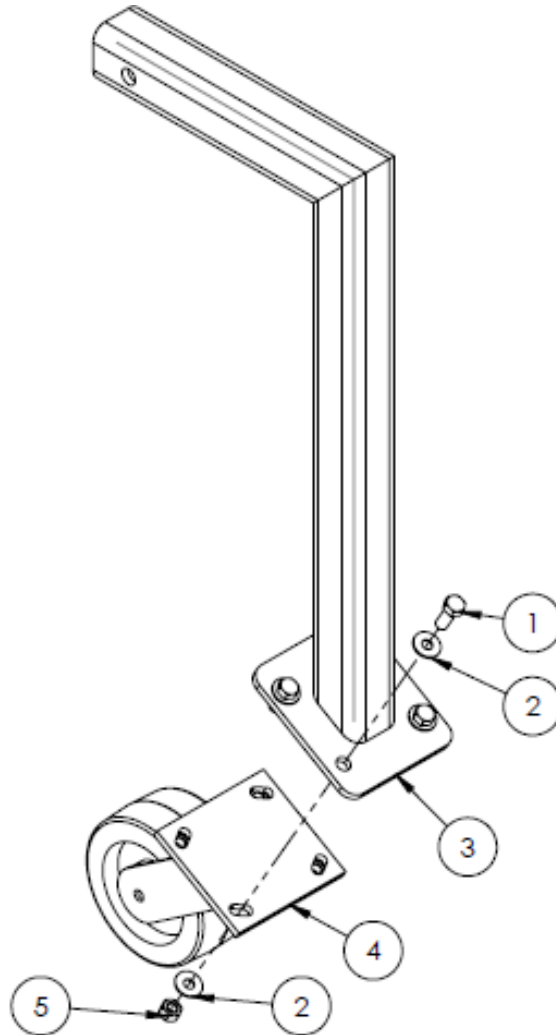

REF	DESCRIPTION	PART #	QTY
1	HEX CAP SCREW 3/8-16 X 1	164-10115	4
2	5/16 USS FW	164-20156	8
3	TRANSPORT WHEEL BRACKET	370-042-04	1
4	TRANSPORT WHEEL	156-040	1
5	3/8-16 STOVER LOK-NUT	164-22834	4

REGULATOR ASSEMBLY DIAGRAM & PARTS

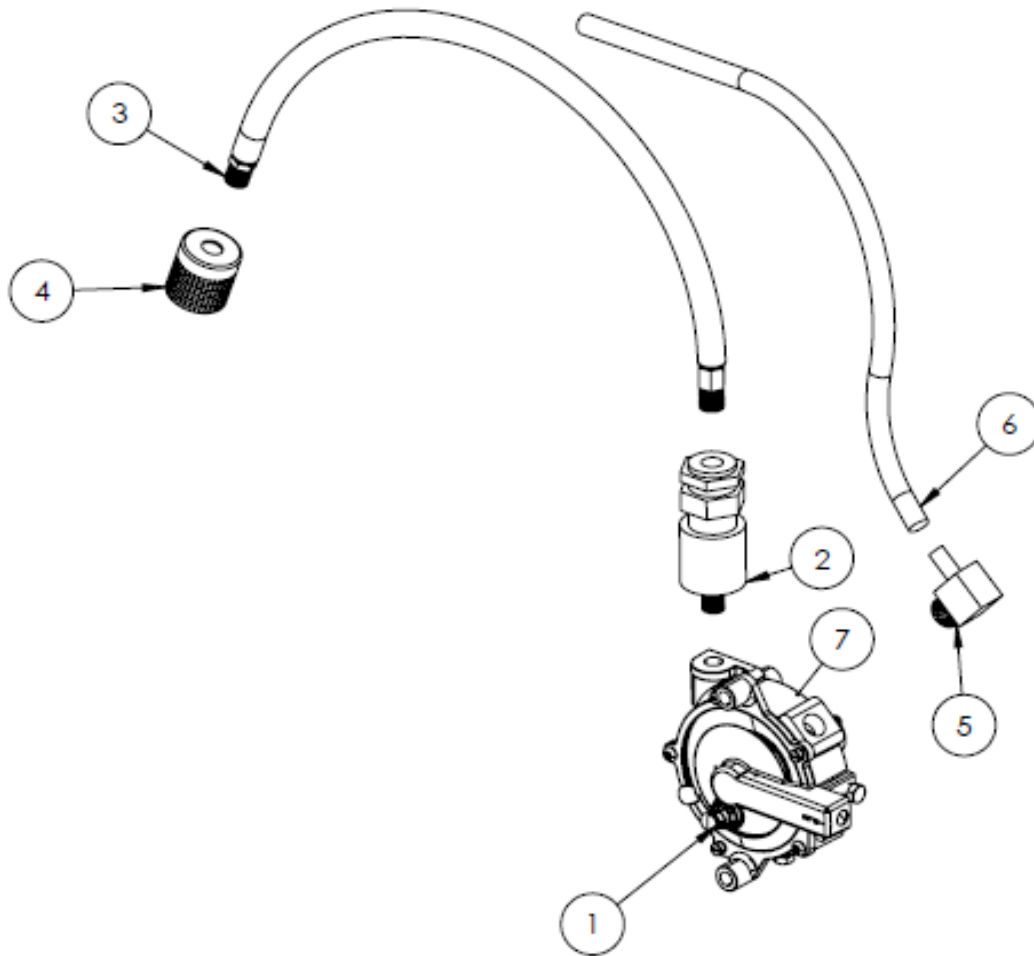

REF	DESCRIPTION	PART #	QTY
1	REGULATOR	152-500	1
2	FUEL LOCK	152-N3-0173-1	1
3	HOSE, LP TANK TO REGULATOR 18"x1/4"	267-P5561-0410	1
4	QUICK COUPLING	152-700	1
5	BRASS ELBOW 3/8 NPT X 1/2" BARB	166-62040-B	1
6	FUEL LINE 37" (SOLD BY THE FOOT)	216-7132-50354	3

PUREPOWERLPG 600 SERIES ENGINE DIAGRAM

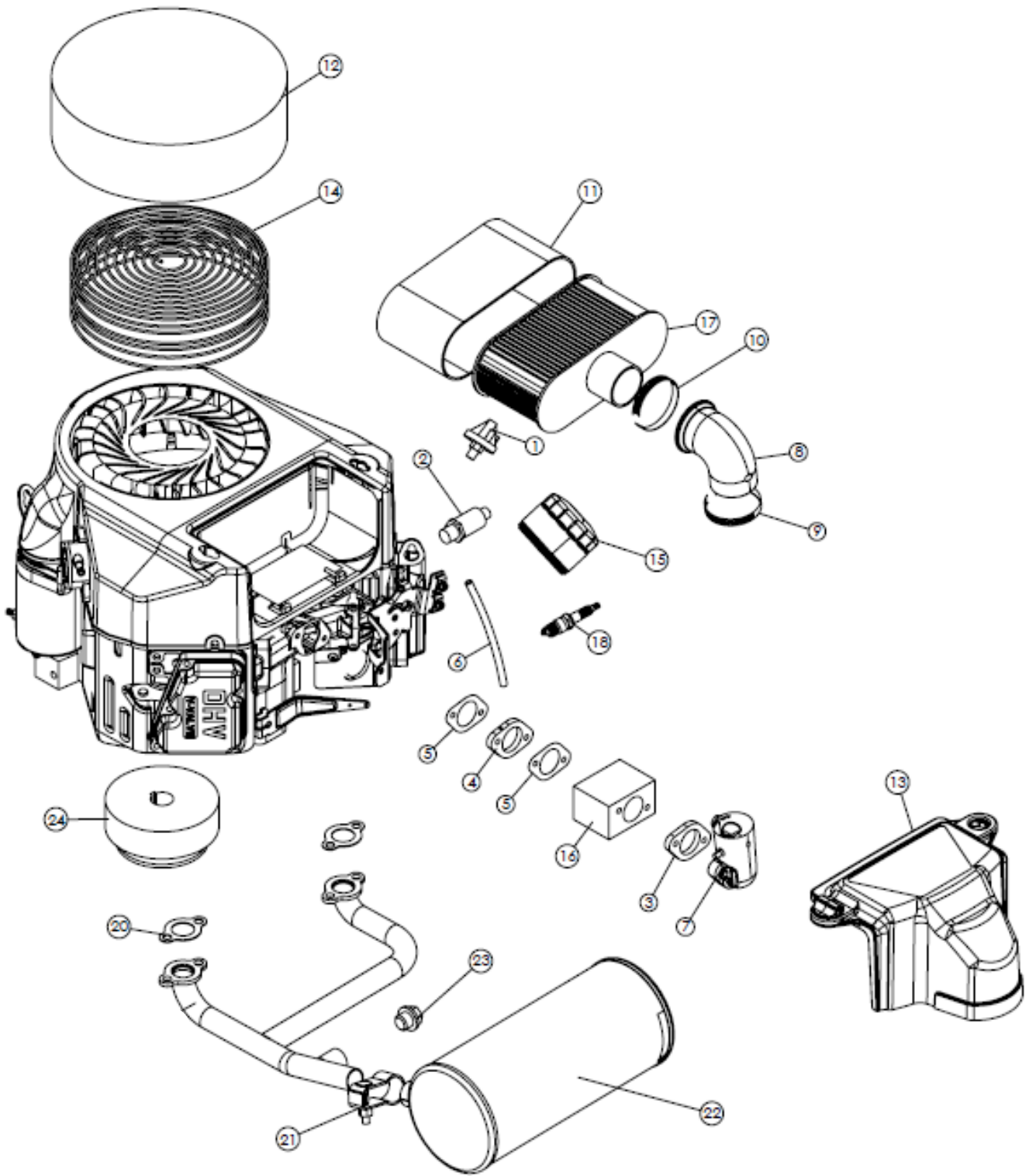

AZTEC PUREPOWERLPG 603cc FS481V ENGINE PARTS

REF	DESCRIPTION	PART #	QTY
1	OIL PRESSURE SWITCH 17HP	152-N3-0082	1
2	VALVE OIL DRAIN 14HP/17HP	312-504-0185	1
3	GASKET AIR FILTER FS481	309-11061-7095	1
4	INSULATOR CARB SPACER FS481	309-16073-7007	1
5	INSULATOR CARB GASKET FS481	309-11061-7096	2
6	TUBE AIR CLEANER FS481	309-92192-7164	1
7	PIPE-INTAKE FS481	309-16060-7036	1
8	TUBE AIR CLEANER FS481	309-92192-7164	1
9	PIPE INTAKE CLAMP FS481	309-92171-7010	1
10	HOSE CLAMP FS481	309-92173-7007	1
11	PRE FILTER CLEANER FS481	309-11013-7046	1
12	FOAM HAT FILTER KW	186-271964	1
13	AIR FILTER COVER FS481	309-11011-7060	1
	Air Filter Cover Wing Nut	309-92210-7038	2
	Air Filter Cover O-Ring	309-92055-7025	2
14	DEBRIS SCREEN FS481	309-18540-603	1
15	FILTER-OIL FS481	309-49065-7007	1
16	CARB (DOES NOT INCLUDE THROTTLE PLATE, SHAFT OR SEAL)	152-CARB	1
17	ELEMENT AIR FILTER FS481	309-11013-7049	1
18	SPARK PLUG BPR4ES	309-92070-7004	2
20	EXHAUST GASKET, MANIFOLD FS481	309-11060-7016	2
21	MUFFLER CLAMP FS481	309-92072-7013	1
22	1 PIECE CATALYTIC MUFFLER MANIFOLD	152-603-BC	1
23	MANIFOLD PLUG	164-M1815P	1
24	CENTRIFUGAL CLUTCH	311-180007	1

DIAMOND DRIVER DIAGRAM & PARTS

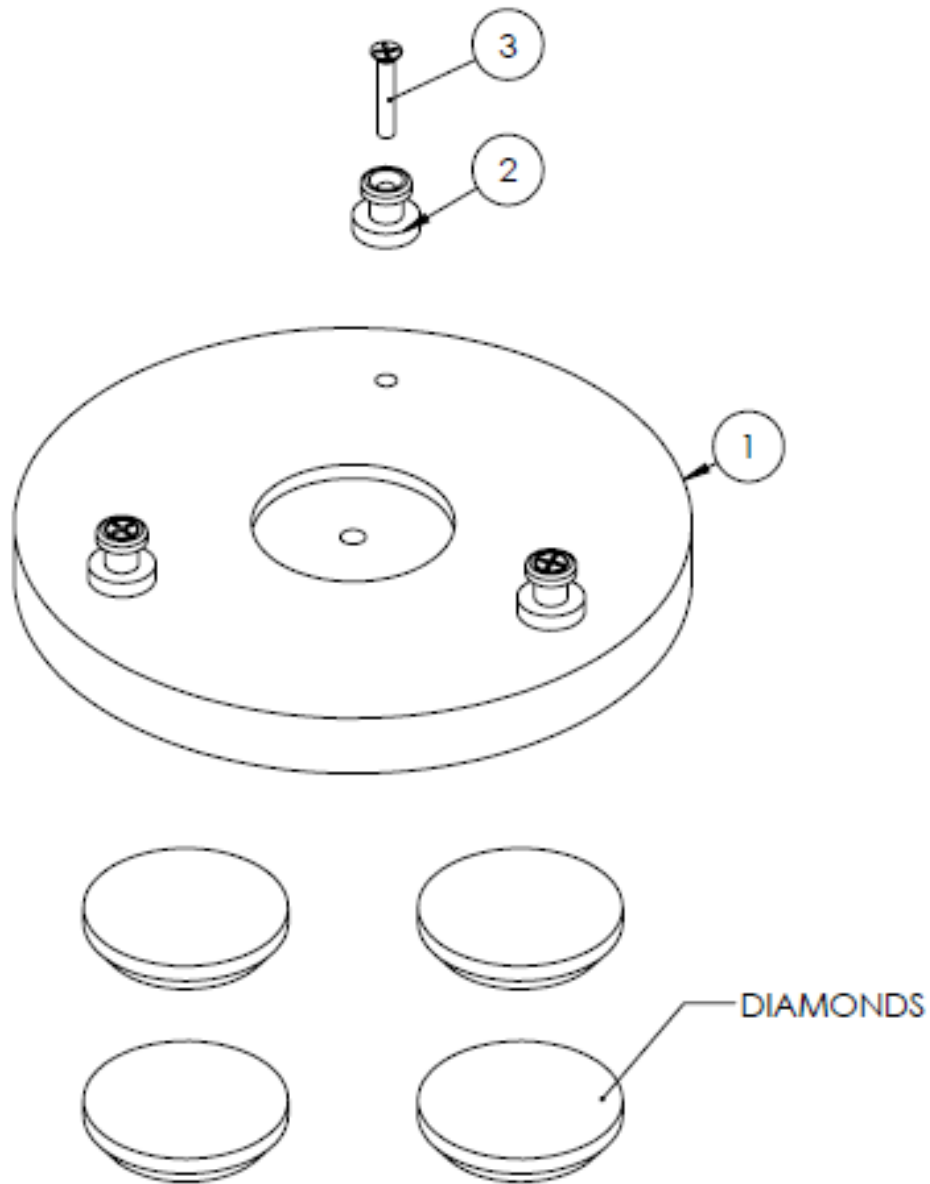

REF	DESCRIPTION	PART #	QTY
1	10" DIAMOND DRIVER ASSEMBLY	042-1-D	3
2	DRIVER LUG	042-80	3 EACH
3	1/4-20 X 1 1/2 PH FLAT MS	164-25C150MXFZ	3 EACH

* Diamonds and pads are each sold separately, contact us for pricing (sales@aztecproducts.com)

PAD DRIVER DIAGRAM & PARTS

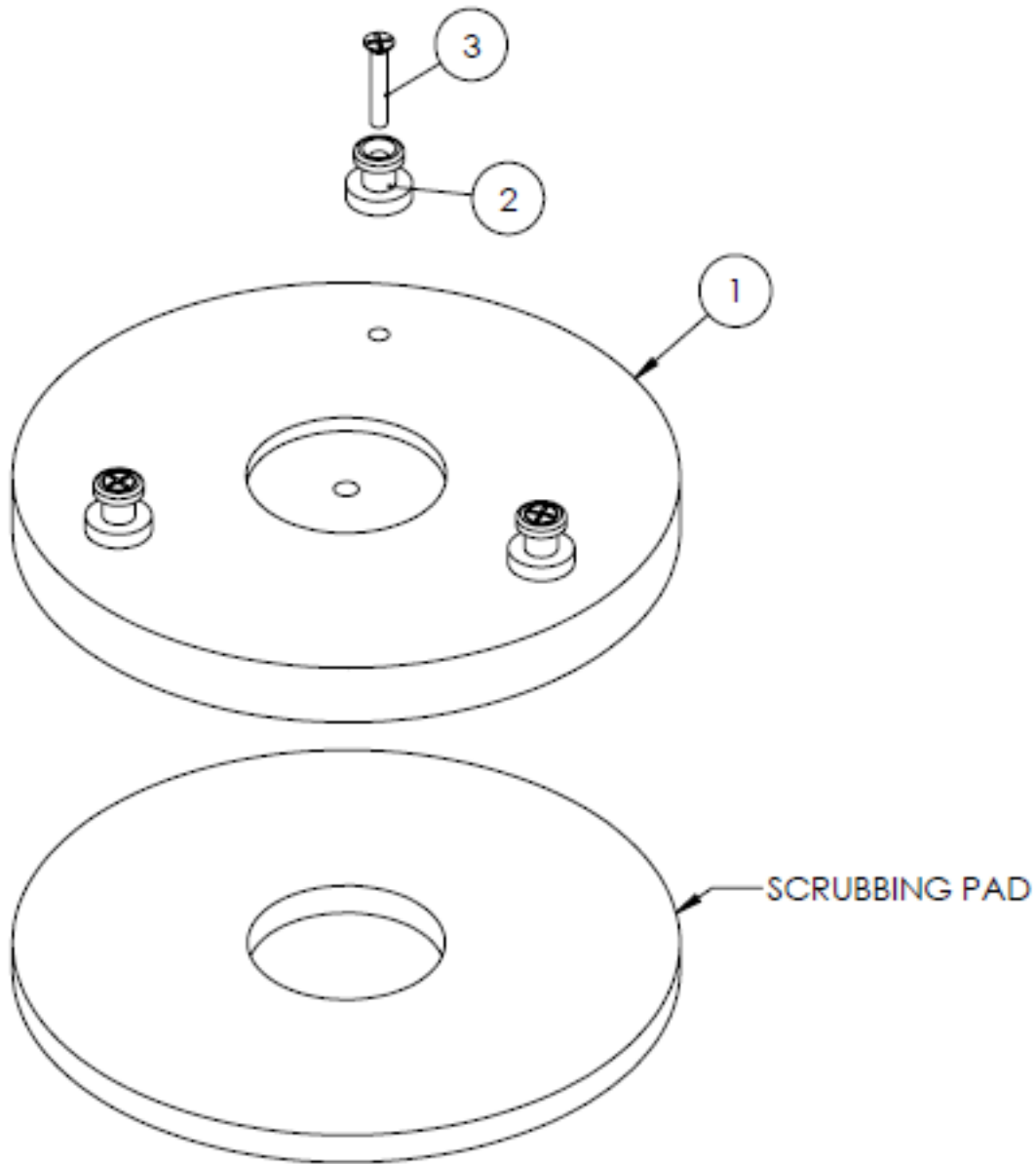

REF	DESCRIPTION	PART #	QTY
1	10" PAD DRIVER ASSEMBLY	042-1-P	3
2	DRIVER LUG	042-80	3 EACH
3	1/4-20 X 1 1/2 PH FLAT MS	164-25C150MXFZ	3 EACH

* Diamonds and pads are each sold separately, contact us for pricing (sales@aztecproducts.com)

STRIP BRUSH DIAGRAM & PARTS

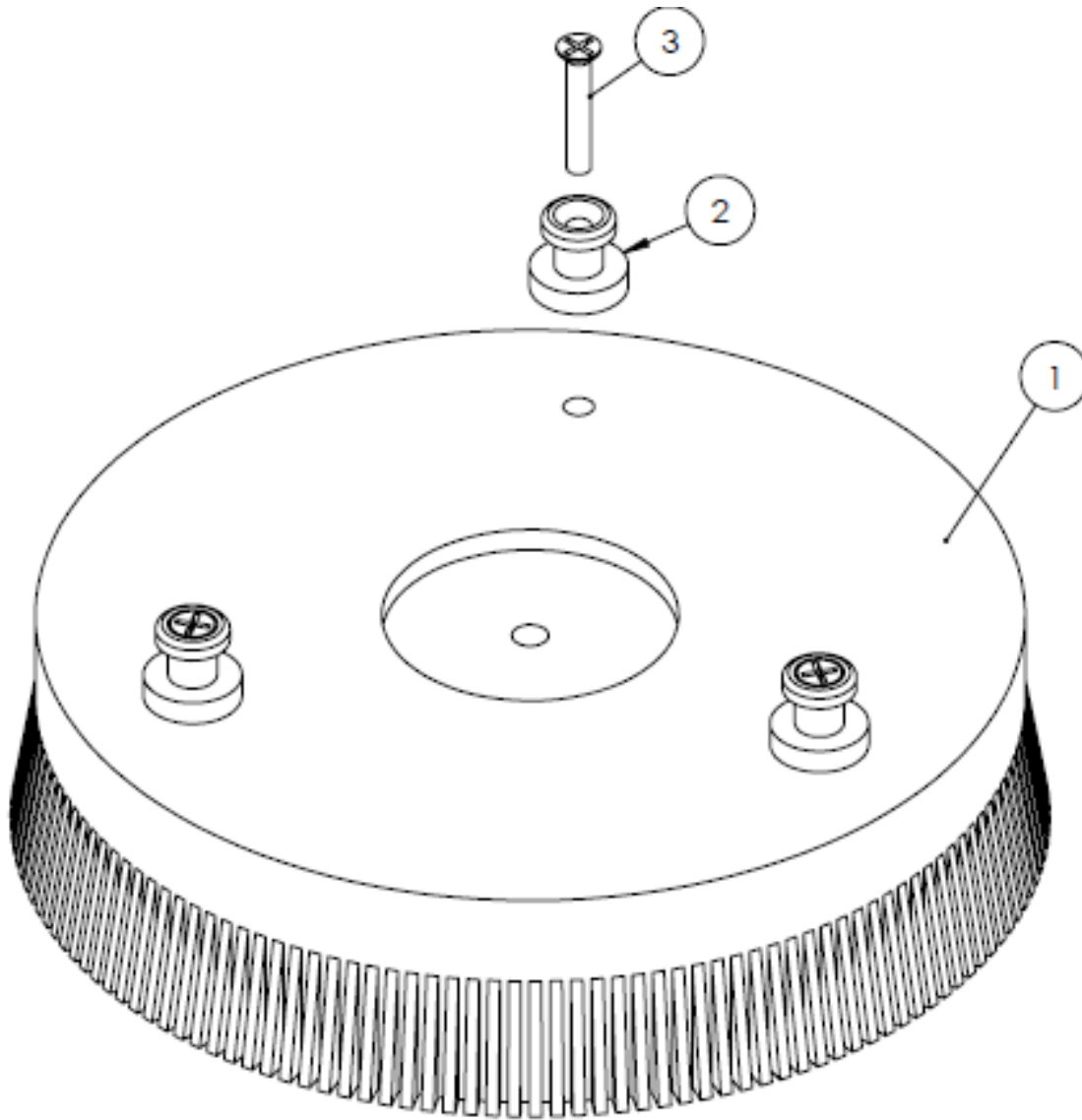

REF	DESCRIPTION	PART #	QTY
1	10" STRIP BRUSH ASSEMBLY	042-1-S	3
2	DRIVER LUG	042-80	3 EACH
3	1/4-20 X 1 1/2 PH FLAT MS	164-25C150MXFZ	3 EACH



Aztec Products, Inc.
201 Commerce Drive
Montgomeryville, PA 18936

ELECTRICAL SCHEMATIC

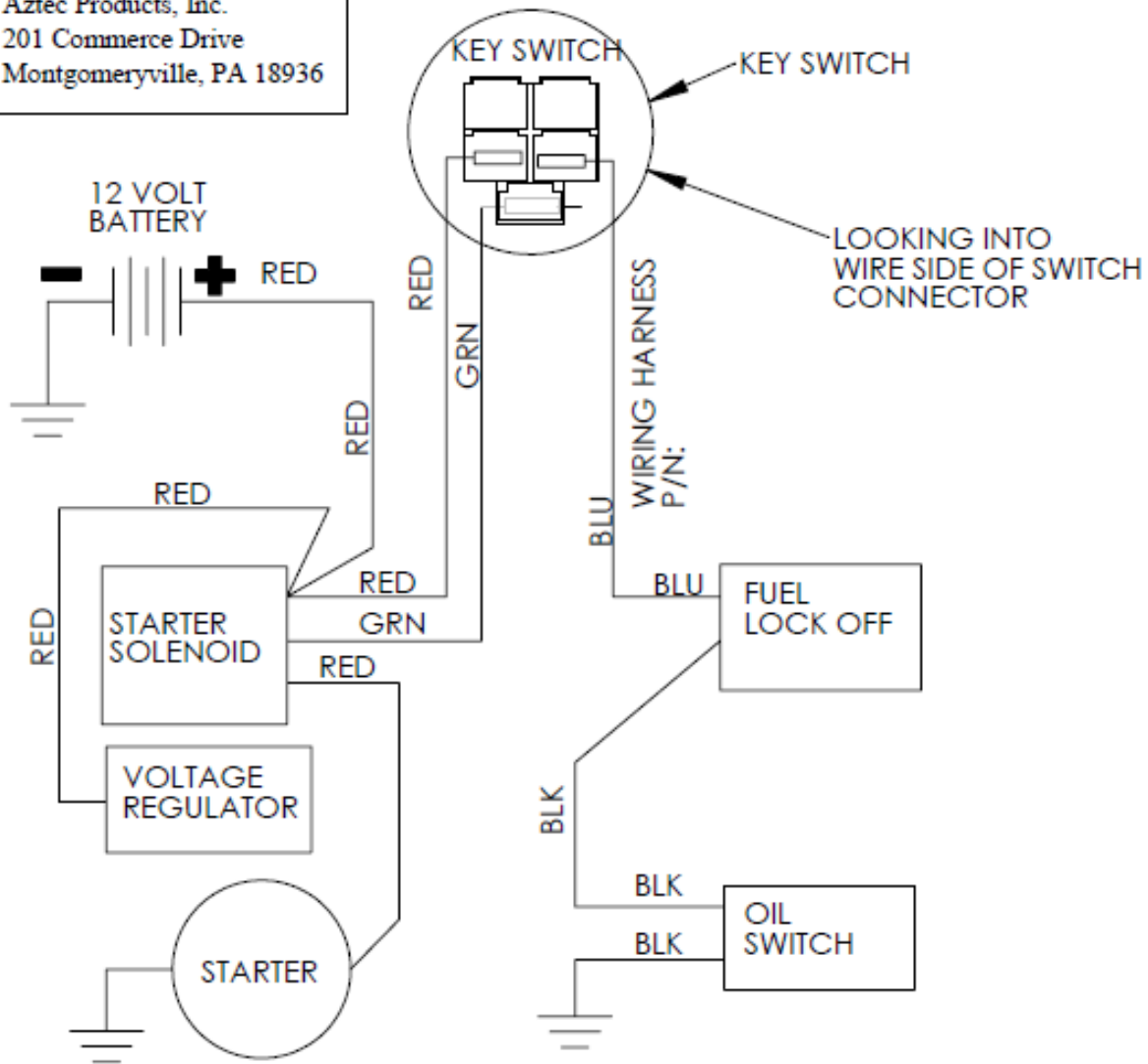

REFER TO KAWASAKI OWNERS MANUAL FOR IGNITION AND CHARGING CIRCUIT SCHEMATIC

LEGEND:
GRN = GREEN
BLK = BLACK
BLU = BLUE
RED=RED

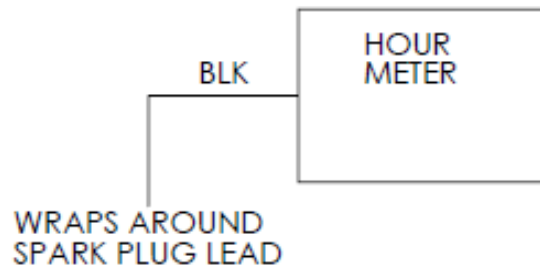

Toll Free: 1.800.331.1423

Email: parts@aztecproducts.com

www.aztecproducts.com

AZTEC REFRESHER WARRANTY

This warranty is limited as follows:

Component	Term of Warranty
Engine	2 yrs from engine manufacturer
Fuel System	1 yr
LPG Tank	1 yr on valve, 3 yrs on cylinder from date of mfgr
Body Parts	1 yr
Battery	1 yr from battery mfgr
Centrifugal Clutch	1 yr

The warranty does not apply to certain consumable or wear parts such as:

Belts, Brushes, Pulleys, Springs
Engine tune up parts

Aztec Products, Inc. warrants its products to be free from defects in material and workmanship for a period of one year from the date of sale. All engines are warranted by the manufacturer for a period of two years when engine maintenance schedules are followed.

The warranty does not apply to damage or failure caused by abuse, misuse, neglect, disassembly, alteration, unauthorized modification or repair, lack of proper maintenance, theft or damage by freight carriers. The warranty applies to parts, labor, and ground freight only. Aztec is not liable for transportation to or from repair centers or travel for on-site repairs. Aztec Products, Inc. will not be liable for incidental or consequential damages arising from the use of any of its products, whether defective or not.

Aztec Products, Inc. agrees, at its discretion, to repair or replace at its own expense any product or part(s) which examination proves to be defective in workmanship or materials provided that the purchaser notifies Aztec Products, Inc. directly within the warranty period and follows the Return Goods Policy. Engine repairs may be performed at engine manufacturer service centers. For your closest center you may call Kawasaki: 616-949-6500 or visit <https://kawasakienginesusa.com>.

In order to obtain parts warranty, the following procedures must be followed:

1. Customer must call Aztec Products, Inc. for an RGA (Return Goods Authorization) Number.
2. Aztec maintains the serial number, date of shipment or sale, and customer name on each piece of equipment sold. If you were the purchaser, please reference that information on your request for replacement or repair. If you purchased the equipment through a distributor, please contact them first. If you are not satisfied, contact Aztec and give us the distributor name, purchase date, and the serial number of the product.
3. The defective part must be returned via ground freight prepaid to Aztec Products, Inc. with an RGA number accompanied by a copy to the original purchase invoice. Aztec is not responsible for the cost of packaging inbound freight, nor inbound freight damage. Pack machine and parts carefully.
4. Only Aztec Products, Inc. or its authorized dealers may make warranty repairs on Aztec Products, Inc. products. Others do so at their own risk and expense.
5. Aztec will do warranty related repairs free of charge at our Montgomeryville, PA facility. Arrangements must be made in advance as outlined above. Aztec will not accept freight collect returns or returns that do not indicate the RGA number on the packing list.

The need for proper maintenance and care for this product cannot be overstated. Poor maintenance, neglect or abuse will void the warranty and prove to be very expensive.

You have purchased a quality product. Each of its components have been tested and approved for use by Aztec Products, Inc. It is unlikely that you will ever have a warranty claim if you properly maintain your machine.

This warranty is non-transferable
AZTEC PRODUCTS, INC • www.aztecproducts.com
201 Commerce Drive • Montgomeryville, PA 18936 • 215-393-4700
Please send your inquiry to: parts@aztecproducts.com