

# OWNER'S MANUAL

## THE LOWRIDER

Propane Burnisher (21", 24" and 27")



[WWW.AZTECPRODUCTS.COM](http://WWW.AZTECPRODUCTS.COM)  
[PARTS@AZTECPRODUCTS.COM](mailto:PARTS@AZTECPRODUCTS.COM)

CALL 215-393-4700 TOLL FREE: 800-331-1423  
201 COMMERCE DRIVE, MONTGOMERYVILLE, PA 18936

## TABLE OF CONTENTS

TABLE OF CONTENTS	PG 2
INTRODUCTION	PG 3
GENERAL SAFETY MESSAGE INFORMATION	PG 3-9
IMPORTANT SAFETY INSTRUCTIONS	PG 4
GUIDE TO GRAPHICAL SYMBOLS AND PRODUCT LABELS	PG 4
GENERAL OPERATION SAFETY INFORMATION	PG 5-7
STORAGE AND HANDLING SAFETY INFORMATION	PG 8
RETAILER/DISTRIBUTOR CONTACT INFO	PG 8
MAINTENANCE SAFETY INFORMATION	PG 9
BEFORE OPERATION CHECKLIST	PG 10-11
LOWRIDER OPERATION	PG 12-14
LOWRIDER - GETTING STARTED	PG 15
LOWRIDER BELT & BRUSH MAINTENANCE	PG 16
STARTING THE ENGINE	PG 16
ADJUSTING PAD PRESSURE	PG 16
STOPPING THE ENGINE	PG 17
LOWRIDER CLEAN-UP	PG 17
NOTES	PG 17
TRANSPORTING THE LOWRIDER	PG 18
STORING THE MACHINE & PROPANE TANKS	PG 18
ENGINE MAINTENANCE SAFETY	PG 19-24
ENGINE MAINTENANCE METER	PG 19
ENGINE OIL & MAINTENANCE	PG 20
RECOMMENDED OIL & OIL LEVEL CHECK	PG 20
OIL CHANGE	PG 21
OIL FILTER CHANGE	PG 21
PUREPOWERLPG™ ENGINE MAINTENANCE SCHEDULE	PG 22
TROUBLESHOOTING - ENGINE	PG 23
ENGINE BATTERY START WIRING DIAGRAM	PG 23
PUREPOWERLPG™ ENGINE TUNE-UP SPECS	PG 24
TROUBLESHOOTING – ELECTRICAL SYSTEM	PG 25
LOWRIDER QUICK START GUIDE	PG 26
SAFETY LABEL LOCATIONS	PG 27
LOWRIDER PREVENTATIVE ENGINE MAINTENANCE KIT	PG 28
PARTS LIST FOR LOWRIDER BODY ASSEMBLY	PG 29-30
LOWRIDER HANDLE ASSEMBLY	PG 31
FUEL SYSTEM PARTS	PG 32
PUREPOWERLPG™ ENGINE PARTS	PG 33-34
WARRANTY	PG 35

## INTRODUCTION

Thank you for purchasing this Aztec Products, Inc. machine. You have purchased a quality product and we welcome you to the Aztec family. It is critically important to utilize proper training, understanding, maintenance and care for this product. Neglect of the Safety Messages, especially the **DANGER**, **WARNING**, **CAUTION** and **NOTICE** statements throughout this Owner's Manual may lead to serious injury or death, and/or cause damage to the floor and/or facility.

For best results from your Aztec machine, you must read and understand this Owner's Manual, and follow all operation guidelines and safety messages. Protect your **WARRANTY** by following all maintenance guidelines and keeping a dated log. If a problem should arise, consult an authorized Aztec service center.

All information in this Owner's Manual is up to date and based on the latest product information available at the time of printing. Aztec Products, Inc. reserves the right to make changes at any time without notice or incurring obligation. This Owner's Manual and the maintenance log must be kept as a permanent part of the machine and remain with the machine if resold.

No part of this document may be copied or reproduced without written permission.

## GENERAL SAFETY MESSAGE INFORMATION

Your safety and the safety of others is very important. As the manufacturer, we have provided important safety messages throughout this manual and on the machine. The purpose of these safety messages is to prevent damage to you, your machine, the property, and/or the environment.

Please read and understand this information thoroughly. A safety message alerts you to potential hazards that could result in injury or death, and/or cause damage to the floor and/or facility. Each safety message is preceded by a universal safety alert symbol (!) and one of these safety words: **DANGER**, **WARNING**, **CAUTION**, or **NOTICE**. These signal words mean:

	<b>DANGER</b> indicates a hazardous situation which, if not avoided, will result in death or serious injury
	<b>WARNING</b> indicates a hazardous situation which, if not avoided, could result in death or serious injury.
	<b>CAUTION</b> indicates a hazardous situation which, if not avoided, could result in minor or moderate injury
	<b>NOTICE</b> is used to address practices not related to physical injury

## IMPORTANT SAFETY INSTRUCTIONS

READ and UNDERSTAND all instructions and safety messages before operating this machine.

Follow the instructions given in this Owner's Manual and the training given by your supervisor for the safe operation of this machine. Failure to do so can result in personal injury and/or damage to the machine or property.

## GUIDE TO GRAPHICAL SYMBOLS AND PRODUCT LABELS



DANGER, WARNING OR CAUTION; read all instructions before using



Hot surface – Do not touch



Wear hearing protection when operating



Wear safety goggles when operating



Switch "On" Position



Switch "Off" position

## GENERAL OPERATION SAFETY INFORMATION

Liquefied petroleum gas (LPG or propane) is stored under pressure and must be handled in the proper manner to be safe. Observe the following safety messages to get the best performance, lowest emissions, and longest life out of your equipment.

### NOTICE

The EPA has rated the PurePowerLPG™ engine cleanest in the industry for CO (carbon monoxide) emissions. (Source: <https://www.epa.gov/compliance-and-fuel-economy-data/engine-certification-data#small-nrsi>).

### DANGER

Because CO is always a byproduct of internal combustion engines, it is important to know the symptoms of CO exposure, which may include drowsiness, dizziness, nausea, vomiting, confusion, collapse, loss of consciousness and muscle weakness. If such symptoms occur during operation with this machine, immediately shut off the machine and go outside for fresh air. Have a qualified service technician test the machine for CO emissions before using again. Call for emergency medical attention and DO NOT operate this machine or other propane powered equipment until cleared by a physician. For more info on CO exposure effects, see <http://www.mayoclinic.org/diseases-conditions/carbon-monoxide/basics/symptoms/con-20025444>.

### DANGER

No smoking, no sparks, no flames near machine, engine or LPG tank. Do not operate this machine in an environment with a potential ignition source.

### DANGER

If you smell gas: immediately stop the unit, check for leaks, open windows, don't touch electrical switches, extinguish any open flames, and contact a repair professional.

### DANGER

Never change or alter the propane control equipment. It is precisely tuned to power machinery with minimal levels of carbon monoxide. Altering the control equipment could cause dangerous levels of engine emissions.

### DANGER

Effective January 1, 2016, all Aztec Products, Inc. machinery is shipped with propane tank equipped with Overfill Protection Device (OPD). If you have an older LPG cylinder that is overfilled, always vent outdoors, away from closed areas where gas may accumulate, and away from any fire, flame, or spark-producing device. Use a screwdriver to vent excess propane, which escapes as a white mist. Propane will vent clear when correct tank level has been achieved.

### DANGER

All Aztec propane powered machines are designed specifically for use with a 20 lb (5 gallon) vertical vapor withdrawal propane cylinder. Use of a different configuration cylinder or liquid withdrawal cylinder is dangerous and could cause fire or explosion, and will void the warranty.

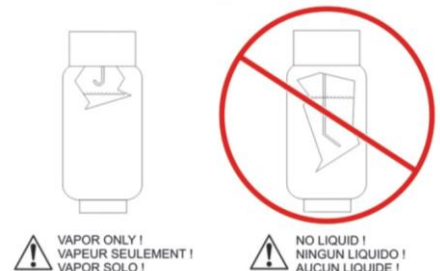

**⚠ WARNING**

Operate only in well ventilated areas. Buildings must be provided with:

- A. A continuous mechanical ventilation that removes the products of combustion to the outdoors of not less than 300 CFM for each 10,000 BTUH or fraction thereof; or
- B. Natural ventilation of not less than 300 CFM for each 10,000 BTUH input or fraction thereof, based on a maximum of one-quarter air exchange per hour for the net building volume.

**⚠ WARNING**

Although this machinery utilizes a catalytic muffler to treat and minimize all engine emissions, the exhaust may still contain trace amounts of chemicals known in the state of California to cause cancer, birth defects or other reproductive harm.

**⚠ WARNING**

Although this PurePowerLPG™ engine is equipped with a catalytic muffler for safety, its exhaust may still contain trace amounts of poisonous CO (carbon monoxide) gas and/or chemicals known in the state of California to cause cancer, birth defects or other reproductive harm. Do not run the engine without adequate ventilation.



**⚠ WARNING**

Keep hands and feet clear of moving parts to avoid injury.

**⚠ WARNING**

**HOT MUFFLER CAN BURN YOU.** Stay away if engine has been running.

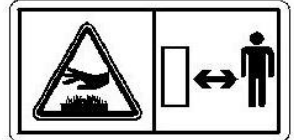

**⚠ CAUTION**

Muffler is HOT. Keep all heat sensitive objects away from the exhaust system during and after operation. Damage can occur to the machine, furniture, buildings and/or personal injury.

**⚠ CAUTION**

Do not operate machine in a stationery spot for more than a few seconds. Machine is designed to be moved continuously forward at a measured pace. Stationary operation will result in damage to floor surface.

**⚠ CAUTION**

Never let an untrained or irresponsible person operate the machine. They may hurt themselves and/or damage the floor or other property.

**⚠ CAUTION**

Always check oil before attempting to start engine. Low oil may result in serious and expensive engine damage.

**⚠ CAUTION**

Never complete the connection of the propane tank to the machine by using a tool; always tighten and loosen by hand. Use of tools to tighten or loosen tank connection may result in damage to tank valve and insecure connection. Listen for the rush of fuel to the lock-out device when you open the tank valve. If you hear this, it will indicate that a good connection has been made at the tank.

**⚠ CAUTION**

Do not leave this machine unattended while the engine is running. Damage to floor surface or other property may occur and fumes may accumulate.

**⚠ CAUTION**

When the LPG tank is attached to the machine and not running, the tank valve must be in CLOSED position.

**NOTICE**

Using the electric starter for more than 10 seconds at a time will overheat the starter motor and can damage it.

**NOTICE**

A "NO SMOKING" sign should be permanently displayed at the storage area.

**NOTICE**

Do not remove machine/engine labels and/or WARNING stickers on machine or engine. If any labels or stickers come lose, contact Aztec ([parts@aztecproducts.com](mailto:parts@aztecproducts.com)) for replacement.

**NOTICE**

Always remove Engine Key from switch when leaving engine will be unattended or when engine is not in use.

## STORAGE AND HANDLING SAFETY INFORMATION

**⚠ DANGER**

Always store equipment away from heater rooms, boilers, gas-fired water heaters or any other source of open flame or ignition. The exhaust system will be very hot and takes several minutes to cool, so keep yourself and all materials clear.

**⚠ DANGER**

Always store equipment away from possible damage by falling objects in warehouse-type areas.

**⚠ DANGER**

Always store LPG tanks outside. Remove all propane tanks from inside building except during equipment use. Store them in a secure, well ventilated area.

**⚠ CAUTION**

If the engine has been running, allow it to cool for at least 15 minutes before loading the engine-powered equipment onto the transport vehicle. A hot engine and exhaust system can burn you and can ignite some materials.

**NOTICE**

This propane-powered machine is intended for commercial use.

**NOTICE**

Safety is a full-time, every day job. Follow all information posted on the machine and the LPG tank. Never allow anyone untrained to operate this machine, and who has not read or cannot understand the given instructions.

### RETAILER/DISTRIBUTOR CONTACT INFO

PURCHASE DATE:

DISTRIBUTOR NAME:

DISTRIBUTOR PHONE NUMBER(S):

### PROTECT YOUR WARRANTY!

**Read carefully; all questions regarding the care and safety of this equipment, please contact AZTEC PRODUCTS:  
parts@aztecproducts.com**

## MAINTENANCE SAFETY INFORMATION

### **⚠ WARNING**

Before attempting any service or maintenance, the engine switch must be in the OFF position and the propane tank valve must be in CLOSED position.

### **⚠ WARNING**

Machine should only be tipped back for service if properly turned OFF, in a safe environment and positioned on a flat surface. Do not tilt machine on its side; damage can occur to the machine, furniture, buildings and/or personal injury.

### **⚠ CAUTION**

Do not tilt machine on its side; damage can occur to the machine, furniture, buildings and/or personal injury. Machine should only be tipped back to transport or for service, if properly turned OFF, in a safe environment and positioned on a flat surface.

### **NOTICE**

The manufacturer's warranty will be voided if the machine is not maintained in accordance with the recommended maintenance instructions within this Owner's Manual, and the engine manufacturer's recommended maintenance procedures. Failure to do so may cause damage to the machine, equipment, furniture, buildings, and/or personal injury.

### **NOTICE**

An abbreviated, quick reference schedule of the manufacturer's suggested maintenance is on the underside of the operating handle. This abbreviated schedule is for quick reference only and is not intended to replace the full maintenance schedule in the Owner's Manual.

### **NOTICE**

A maintenance record must be kept, indicating all dates of service, hours on engine at time of service, and service performed to maintain manufacturer's warranty coverage. Perfect record keeping does not guarantee warranty coverage if the damage to the machine is non-warrantable. See warranty coverage policy details at the end of this Owner's Manual. The maintenance record must be kept with the machine and transferred to the new owner if resold.

## BEFORE OPERATION CHECKLIST

For your safety, to ensure compliance with environmental regulations, and to maximize the service life of your equipment, it is very important to take a few minutes before you operate this machine to check its condition. Be sure to take care of any problem you find, or have your service dealer correct it before you operate this machine.

### **WARNING**

Improperly maintaining this machine and its engine, or failure to correct a problem before operation, may cause a malfunction in which you can be seriously hurt or killed. Always perform a pre-operation inspection before each use, and correct any problem.

### **WARNING**

Avoid use in areas with floor obstruction such as thresholds and floor outlet boxes. Avoid use in areas with loose debris or small objects that may become caught in the rotating pad.

Before beginning your pre-operation checklist, the machine and engine must be on a level surface, with the engine switch in the OFF position, and the propane tank valve is in the CLOSED position. Always check the following items before you start the engine:

#### **A. READ AND UNDERSTAND ALL SAFETY MESSAGES**

Carefully read and understand all **SAFETY INSTRUCTIONS** on pgs 3-9.

#### **B. CHECK THE GENERAL CONDITION OF THE MACHINE**

- 1.) Look around and underneath the machine and engine for signs of oil leaks.
- 2.) Remove any excessive dirt or debris, especially around the muffler and recoil starter.
- 3.) Look for signs of damage.
- 4.) Check that all shields and covers are in place, and all nuts, bolts and screws are tightened.
- 5.) Address all of the above issues before proceeding.

#### **C. CHECK THE ENGINE**

- 1.) Check the engine oil level and filters. Running the engine with a low oil level can cause engine damage. Your first oil change should be after the first 8 hours of use.
- 2.) Check the air filter element (see pg 32). A dirty air filter element will restrict air flow to the carburetor, reducing engine performance.

#### **D. CHECK THE MAINTENANCE SCHEDULE**

Review the maintenance log that must be kept with the machine. Perform any maintenance necessary before proceeding. All machines are equipped with a multi-function maintenance meter. The functions include the following: hour meter, service alert and tachometer. (See **ENGINE MAINTENANCE METER** instructions on pg 19).

**E. CHECK THE ENGINE OIL**

Make sure the machine is level when checking the oil. Always take two (2) readings of the dipstick before adding oil. If the oil level is below the full mark, add just enough oil to the engine to bring the oil level up to the full mark. Never over fill. Check for foreign material on the dipstick.

**F. CHECK THE PROPANE/LPG TANK AND LINES**

- 1.) Every tank has been pressure and leak tested. However, every time a tank is filled and/or connected to the machine it should be soap tested. All LPG lines must be pressurized, and every inch of line and connections must be sprayed. If you find a leak, make the proper repairs before operating the machine.
- 2.) Never overfill the LPG tank. The LPG tank is designed to hold a maximum of 20 pounds of propane. Make sure to weigh the tank as it is being filled. The gross weight of a full tank should not exceed 48 pounds. If, while operating the machine, you notice frost forming on the LPG lines or the regulator, your tank has been over filled. If you continue to operate the machine in this condition, damage will occur. The excess propane in the tank must be removed before normal operations resume. The bleeding of a propane tank must be done in a safe manner; refer to the **GENERAL OPERATION SAFETY INFORMATION** on pgs 3-9. In some cases, the regulator must defrost before restarting the engine.
- 3.) To connect the high pressure hose to the LPG tank, make sure the couplers are in line and screwed together, hand tight. If this is not done properly, fuel will not pass through to the regulator. Never complete the connection of the tanks to the machine by using a tool; refer to the **GENERAL OPERATION SAFETY INFORMATION** on pgs 3-9.

**G. INSTALL FRESH PADS OR BRUSHES**

- 1.) Never tilt back machine while engine is running. Turn off engine and shut off propane tank. Do not tilt machine on its side; damage can occur to the machine, furniture, buildings and/or personal injury. Machine should only be tipped back to transport or for service, if properly turned OFF, in a safe environment and positioned on a flat surface.
- 2.) To install a fresh pad, lean the machine back and safely secure. Unscrew and remove the pad-centering ring. Remove the old pad and center the new pad onto the pad driver. Reinstall the pad-centering ring. Never "flip" a pad.

Keep the pad with the same side down throughout the life of the pad. Even after a pad is cleaned, you can tell the down side by the centering ring indentation. This practice will increase the pad life and help maintain a properly functioning pad driver.

## LOWRIDER OPERATION

### **CAUTION**

The LowRider must be secured on a level surface when transporting in a vehicle. Secure the machine in the vehicle so it cannot move or bounce during transporting; damage may occur to the machine and/or the vehicle and surrounding objects.

This propane burnishing machine is designed for buffing and polishing VCT and concrete floors; with its low 3 ¾" profile, the LowRider will burnish under racks and hard to reach areas. The LowRider includes an advanced composite polymer pad driver. No other application of this equipment should be attempted nor is recommended. Contact Aztec ([parts@aztecproducts.com](mailto:parts@aztecproducts.com)) for any additional application questions.

The LowRider is available and is available in 21", 24" and 27" pad sizes, with optional upgrades including Dust Control and Spray Mist options. Contact Aztec ([parts@aztecproducts.com](mailto:parts@aztecproducts.com)) for more information.

First, refer to the **SAFETY INFORMATION** on pgs 3-9, and complete the **BEFORE OPERATION CHECKLIST** on pgs 10-11.

### **WARNING**

Never tilt back machine while engine is running. Objects may fly out from underside of machine and damage can occur to the machine, furniture, buildings and/or personal injury.

### **WARNING**

The engine and exhaust become very hot during operation. Keep the engine at least 1 meter (3 feet) away from buildings and other equipment. Keep flammable materials away, and do not place anything on the engine while it is running.

### **CAUTION**

Factory engine speed is set at approximately 3400 RPM. Tampering with the settings will void the warranty and injury can result. Refer to the equipment specifications.

### **CAUTION**

Continuous exposure to high noise levels can cause hearing loss. Although not required by OSHA based on engine volume, hearing protection is recommended while the machine is in operation. In compliance with OSHA regulations, the operational weighted sound level of this machine is less than 89dB(A).

### **CAUTION**

Do not use machine with a damaged or disintegrated pad, to avoid excess vibration.

**NOTICE**

Prolonged exposure to machine vibration may cause tingling or numbness in the fingers and hands. Use of gloves and limits to operator vibration exposure are recommended to prevent such symptoms. The operational hand/arm vibration level of this machine is less than 2.5m/s<sup>2</sup>.

**NOTICE**

Per OSHA standards, ear protection is not required, but is suggested during operation.

**NOTICE**

All machines are equipped with tamper proof fuel systems. If a fuel problem exists, contact an authorized service center.

**NOTICE**

All machines are equipped with a multi-function maintenance meter. The functions include the following: hours, service alert and tachometer; see **ENGINE MAINTENANCE METER** instructions on pg 19.

**NOTICE**

Engine speed not to exceed 3400 RPM.

**NOTICE**

Some machines may include an optional centrifugal clutch. If equipped, the clutch will disengage when the engine RPM is lower than 1500 RPM; the pad will stop.

**NOTICE**

This machine is not suitable for picking up hazardous dust.

**NOTICE**

Do not use this machine on surfaces with a gradient exceeding 2%.

**NOTICE**

Make sure the operator receives adequate instruction before operating the equipment.

**NOTICE**

Do not allow children to operate the machine. Keep children and pets away from the area of operation.

**NOTICE**

Never “flip” a pad. Keep the same side down throughout the life of the pad. Even after a pad is cleaned, you can tell the down side by the centering ring indentation. This practice will increase the pad life and help maintain a properly functioning pad driver.

**NOTICE**

Your new propane powered machine includes a new, empty, vertical LPG propane tank with OPD (Overfill Prevention Device). This is a safety shutoff device incorporated into the filling valve of the propane tank. The OPD valve is designed to prevent cylinder overfilling in excess of the cylinder's maximum permitted filling limit. This valve is provided by the LPG tank manufacturer and may malfunction. The OPD is not to be relied upon in filling the LPG tank; the propane tank is to be filled by weight or by use of a fixed liquid level gauge. The OPD is a backup safety device only.

**NOTICE**

Your new machine has a **Carbon Monoxide (CO) detection badge**; please keep in mind the following important notes about this CO sensor:

- \* Once opened, the CO detection badge will expire in 90 days, so write the open date on the badge when installing on your machine.
- \* The CO detection badge is individually wrapped and must be unwrapped for detector to function.
- \* To apply, simply unwrap the badge, remove the orange backing and apply to the handle assembly of your propane machine, somewhere easily visible to the operator.
- \* The CO detection badge is a passive carbon monoxide detector and can detect as little as 100 parts per million (ppm) carbon monoxide gas at an approximate relative humidity range of 33 to 50%. If the humidity is very high it can detect concentrations as low as 20ppm.
- \* If CO is present in the area, the circle indicator will change color (from orange-red to red-brown, and then to gray-black as the concentration levels increase).
- \* Once the CO detection badge is exposed to fresh air it will return back to orange-red and may be reused.
- \* There is no alarm function and requires no power, but must be visible and seen to determine whether CO is present in the area.
- \* The CO detection badge will be inactivated and damaged by the presence of halogens (iodine, chlorine, bromine), and ammoniac or nitrous gases.

## LOWRIDER – GETTING STARTED

### NOTICE

Responsibly dispose of used pads; always dispose of old materials with the environment in mind.

### NOTICE

Do not operate the machine in one location for more than a few seconds; this will damage, or “burn” the finish.

### NOTICE

The LowRider is not designed for scrubbing operations.

- 1.) Once all of the **BEFORE OPERATION CHECKLIST** on pgs 10-11 is completed, open the LPG tank valve (counter clockwise).
- 2.) To install pad, tilt machine back and secure in place. To tilt back the machine safely, refer to **TRANSPORTING THE MACHINE** on pg 18.
- 3.) Once the machine is securely tipped back in position, remove the pad. Remove and responsibly dispose of the old pads. Be sure to center the new pad in the center of the pad holders. For brushes, turn clockwise to remove, and counter clockwise to install new brushes.
- 4.) Return machine back to level position before proceeding.
- 5.) Adjust the machine handle to comfortable position using pin provided to secure in place.
- 6.) Open the LPG tank valve by turning counter clockwise.
- 7.) Set the throttle control switch to the SLOW position.
- 8.) Turn key to START position until engine starts. Starter should not be engaged for more than 10 seconds at a time. If hard starting is a problem, carefully review **BEFORE OPERATION CHECKLIST** on pgs 10-11. As soon as engine starts, move throttle cable to desired engine speed. If machine includes optional centrifugal clutch, the clutch will disengage when throttle is moved to the SLOW position.
- 9.) Follow the machine in a moderate walking speed; keep moving forward.
- 10.) When your day is done, carefully complete the **LOWRIDER CLEAN UP** steps on pg 17. Always clean and maintain your equipment, and keep accurate records of service and maintenance to maintain the warranty. Refer to the **MAINTENANCE SCHEDULE** on pg 22.
- 11.) To properly store equipment, refer to the **STORAGE AND HANDLING SAFETY INFORMATION** on pg 8.

## BELT INSPECTION & REPLACEMENT

### 1.) INSPECTION:

- a.) Move engine switch to the OFF position, and the propane tank valve in the CLOSED position. Carefully tilt machine back on rear of body and handle. Refer to **TRANSPORTING THE LOWRIDER** on pg 18.
- b.) If belt is worn, cracked or shredding, belt needs to be replaced.

### 2.) REPLACEMENT:

- a.) Place 3/4" wrench on end of the shaft on the top of the body.
- b.) Turn pad driver counter-clockwise to remove pad.
- c.) Take belt off by turning 3/4" wrench on shaft and removing belt from pad driver pulley and engine crank pulley.
- d.) Check pad driver pulley & engine crank pulley for correct alignment.
- e.) Install new belt on engine crank pulley and pad driver pulley, using 3/4" wrench.
- f.) Install belt on tension pulley
- g.) Install pad drive onto shaft, and return machine to safe operating position.

## STARTING THE ENGINE

Understand the operation of all controls and learn how to stop the engine quickly in case of emergency.

- 1.) Once the **BEFORE OPERATION CHECKLIST** on pgs 10-11 is completed, adjust the machine handle to comfortable position using pin to secure in place.
- 2.) Open the LPG tank valve by turning counter clockwise.
- 3.) Set the throttle control switch to the SLOW position.
- 4.) Push the "START" button until engine starts. Starter should not be engaged for more than 10 seconds at a time. If hard starting is a problem, carefully review **BEFORE OPERATION CHECKLIST** on pgs 10-11. As soon as the engine starts, immediately move throttle cable into desired engine speed.
- 5.) Begin operation of machine.

## ADJUSTING PAD PRESSURE

The pad pressure may be adjusted by moving the wheels:

- Forward to reduce weight on the buffer pad, OR
- Backward to increase the weight

This adjustment may be required to adjust to different floor finishes or to the weight variance of aluminum or steel propane tanks.

## STOPPING THE ENGINE

Turn the propane tank valve clockwise to CLOSED position and turn the engine key to OFF position. Refer to **TRANSPORTING THE MACHINE** below, and **MACHINE CLEAN-UP** and **STORING THE MACHINE & PROPANE TANKS** on pg 18.

## LOWRIDER CLEAN UP

First, refer to the **SAFETY INFORMATION** on pages 3-9. The machine must be on a level surface, with the engine switch in the OFF position, and the propane tank valve in the CLOSED position. The manufacturer and engine warranty will be voided if the equipment is not properly maintained.

- A. Turn the propane tank valve clockwise to CLOSED position and turn the engine key to OFF position.
- B. Review the **TRANSPORTING THE LOWRIDER** steps below to properly tilt back the machine and secure in place before moving to next step.
- C. Check the machine for possible loose nuts and bolts; tighten and secure as needed.
- D. The Foam Hat, or engine dust filter, should be removed and cleaned periodically by shaking out the accumulated dust and rinsing with water and a mild detergent. Squeeze out the excess water. Allow the filter to air dry before replacing. Failure to keep the engine dust filter clean may result in engine overheating.
- E. The air filter should be cleaned.
- F. Return the machine to leveled operating position.

### NOTES:

## TRANSPORTING THE LOWRIDER

### CAUTION

The LowRider must be secured on a level surface when transporting in a vehicle. Secure the machine in the vehicle so it cannot move or bounce during transporting; damage may occur to the machine and/or the vehicle and surrounding objects.

First, refer to the **SAFETY INFORMATION** on pgs 3-9. Refer to **LOWRIDER CLEAN UP** above. The machine must be on a level surface, with the engine switch in the OFF position, and the propane tank valve in the CLOSED position. The manufacturer and engine warranty will be voided if the equipment is not properly maintained.

To transport the LowRider, first review the **MAINTENANCE SAFETY INFORMATION** on pgs 3-9.

The machine must be on a level surface, with the engine switch in the OFF position, and the propane tank valve in the CLOSED position. If the engine has been running, allow to cool at least 15 minutes before loading the engine-powered equipment on a transport vehicle. A hot engine and exhaust system can burn you and can ignite some materials.

- 1.) Remove the propane tank from the machine, or disconnect the connection and securely fasten tank to machine. Adjust handle of machine to comfortable position to tilt back.
- 2.) Pull the LowRider in reverse behind you, or push forward by slightly tilting the machine back, raising the brush off floor.
- 3.) When loading up a ramp into a vehicle, the machine should be pulled back rather than pushed forward, to prevent tipping over.

## STORING THE MACHINE AND PROPANE TANKS

Once the job is complete for the day/night, remove the propane tank from the machine and store the tank in a well ventilated approved area. Complete the **MACHINE CLEAN UP** list on pg 17, and follow steps for **TRANSPORTING THE MACHINE** on pg 18. Store your machine in a safe and secure area. Refer to the **SAFETY INFORMATION** on pgs 3-9.

## ENGINE MAINTENANCE SAFETY

Some of the most important safety precautions follow. However, we cannot warn you of every conceivable hazard that can arise in performing maintenance. Only you can decide whether or not you should perform a given task.

Consistent maintenance is essential for safe, economical and trouble-free operation. It will also help reduce pollution.

Follow the **MAINTENANCE SCHEDULE** on pg 22. Remember that this schedule is based on the assumption that your machine will be used for its designed purpose. Sustained high-load or high-temperature operation, or use in unusually wet or dusty conditions, will require more frequent service.

### **WARNING**

Failure to following maintenance instructions and precautions can cause you to be seriously hurt or killed. Always follow the procedures and precautions in this Owner's Manual and the Engine Manufacturer's Manual.

### **WARNING**

Improper maintenance, or failure to correct a problem before operation, can cause a malfunction in which you can be seriously hurt or killed. Always follow the inspection and maintenance recommendations and schedules in this Owner's Manual.

To properly care for and maintain your machine and its engine, follow the recommended engine maintenance schedule, routine inspection procedures and simple maintenance procedures using basic hand tools. Other service tasks that are more difficult, or require special tools, are best handled by professionals and are normally performed by an authorized technician or other qualified mechanic.

The maintenance schedule applies to normal operating conditions. If you operate your engine under severe conditions, such as sustained high-load or high temperature operation, or use in unusually wet or dusty conditions, consult an authorized service center for recommendations applicable to your individual needs and use.

Maintenance, replacement, or repair of the emission control devices and systems may be performed by an engine repair establishment or individual, using parts that are "certified" to EPA standards.

## ENGINE MAINTENANCE METER

This multi-function meter acts as a preventive maintenance tool, which benefits you with increased fuel economy, less down-time and longer engine life.

The meter displays are:

- **Hour Meter:** Displays total run hours when machine is off.
- **Tachometer:** Indicates engine RPM during operation.
- **Service Alert:** The display flashes to alert you to lube and change the oil at 25 hour intervals. After the service is complete, the meter can be reset by pushing the reset button on the face of the meter. It is recommended to keep an additional maintenance log to keep track of oil changes.

## ENGINE OIL AND MAINTENANCE

### **⚠ WARNING**

Hot engine oil can cause severe burns. Allow engine temperature to drop from hot to warm level before attempting to remove oil filter.

### **⚠ WARNING**

Check the engine oil daily before starting the engine, otherwise shortage of the engine oil may cause serious damage to the engine such as seizure.

### **⚠ WARNING**

Engine oil is a toxic substance. Dispose of used oil properly. Contact local authorities for approved disposal methods or possible recycling.

Refer to the **SAFETY INFORMATION** on pgs 3-9. Also refer to the **BEFORE OPERATION CHECKLIST** on pgs 10-11 before operating this machine. Then carefully follow these guidelines:

#### A.) RECOMMENDED OIL (STANDARD OIL 10W30)

The following engine oils are recommended: **API Service Classification: SF, SG, SH, or SJ.**

#### B.) CHECK THE OIL

- 1) Check the engine oil daily before starting the engine otherwise shortage of the engine oil may cause serious damage to the engine such as seizure.
- 2) To check the oil, the engine should be turned OFF, and the machine should be on a level surface.
- 3) Clean the area around the oil gauge before removing it.
- 4) Remove the oil gauge and wipe it with a clean cloth.
- 5) Pour the oil slowly to "FULL" mark on the oil gauge.
- 6) Insert the oil gauge into the tube WITHOUT SCREWING IT IN.
- 7) Remove the oil gauge to check the oil level. The oil level should be between "ADD" and "FULL" marks. Do not overfill.
- 8) Install and tighten the oil gauge.

#### C.) OIL VISCOSITY

Choose the viscosity according to the temperature as follows:

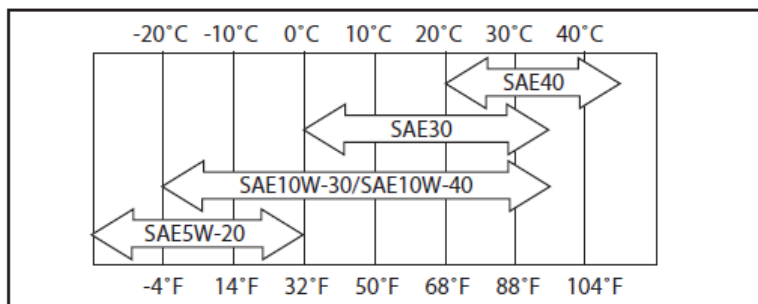

**NOTICE**

Using multi-grade oils (5W-20, 10W30, and 10W-40) will increase oil consumption. Check oil level more frequently when using them.

**D.) ENGINE OIL CAPACITY** (FS481, FS500V, FS541V, FS600V engines)

1.5 L (1.6 US qt) when oil filter is not removed

1.7 L (1.8 US qt.) when oil filter is removed

**E.) OIL CHANGES**

Change oil after first 8 hours of operation. Thereafter change oil every 50 hours. Refer to the **PurePowerLPG™ ENGINE MAINTENANCE SCHEDULE** on pg 22.

- Run the engine to warm oil.
- Be sure the engine (equipment) is level.
- Stop the engine.
- Open the oil drain valve and drain the oil into suitable container while engine is warm.

**F.) OIL DRAIN PLUG**

- Close the oil drain valve.
- Remove oil gauge and refill with fresh oil (See **RECOMMENDED OIL** on page 20).
- Check the oil level (refer to the **BEFORE OPERATION CHECKLIST** on pages 10-11 for **OIL LEVEL CHECK**). Also, refer to the **PurePowerLPG™ ENGINE MAINTENANCE SCHEDULE** on pg 22.

**G.) OIL FILTER CHANGE**

Change the oil filter every 100 hours of operation. Refer to the **PurePowerLPG™ ENGINE MAINTENANCE SCHEDULE** on pg 22.

**CAUTION**

Before removing the oil filter, place a suitable pan under filter connection.

- Drain engine oil into a suitable container.
- Rotate the oil filter (A) counterclockwise to remove it.
- Coat a film of clean engine oil on seal of new filter.
- Install new filter rotating it clockwise until seal contacts mounting surface (B). Then rotate filter 3/4 turn more by hand.
- Supply engine oil as specified.
- Run the engine for about 3 minutes, stop engine, and check oil leakage around the filter.
- Add oil to compensate for oil level drop due to oil filter capacity (refer to the **BEFORE OPERATION CHECKLIST** on pgs 10-11 for **OIL LEVEL CHECK**).

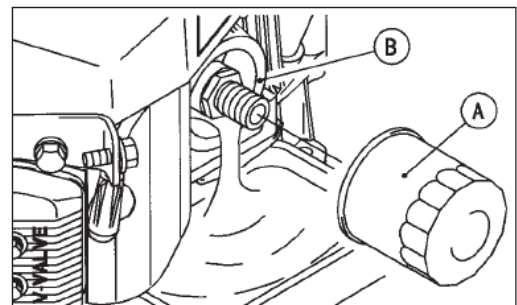

## ENGINE MAINTENANCE SCHEDULE

MAINTENANCE	INTERVAL						
	Daily	First 8 hr.	Every 25 Hr.	Every 50 hr.	Every 100 hr.	Every 200 hr.	Every 300 hr.
Check and add engine oil	•						
Check for loose or lost nuts and screws	•						
Check for fuel and oil leakage	•						
Check battery electrolyte level	•						
Check or clean air intake screen	•						
Clean air cleaner foam element			•				
Clean air cleaner paper element				•			
Clean dust and dirt from cylinder and cylinder head fins					•		
Tighten nuts and screws					•		
Change engine oil		•		•			
Clean and gap spark plugs					•		
Change oil filter					•		
Replace air cleaner paper element					•		
Clean combustion chambers							•
Clean and adjust valve clearance				•*			•
Clean and lap valve seating surface							•

\*After the 1st 50 hours

### NOTICE

Failure to follow the above maintenance schedule could result in non-warrantable failures.

### NOTICE

The engine maintenance schedule is also on the underside of the handle of your machine for easy reference.

### NOTICE

An authorized Kawasaki servicing dealer knows your engine best and is fully equipped to maintain and repair it. To ensure the best quality and reliability, use only new genuine Kawasaki parts or their equivalents for repair and replacement.

## EMISSION CONTROL SYSTEM INFORMATION

PurePowerLPG™ utilizes lean carburetor settings and other systems to reduce the emissions of carbon monoxide, oxides of nitrogen, and hydrocarbons.

### Tampering and Altering

Tampering with or altering the emission control system may increase emissions beyond the legal limit. Among those acts that constitute tampering are:

- Removal or alteration of any part of the intake, fuel, or exhaust systems.
- Altering or defeating the governor linkage or speed-adjusting mechanism to cause the engine to operate outside its design parameters.
- Tampering with the settings will void the warranty and injury can result. Refer to the equipment specifications.

## TROUBLESHOOTING - ENGINE

COMMON PROBLEMS & PROBABLE CAUSES	SOLUTIONS
Engine cranks but will not start: Propane tank is empty Shutoff valve is closed Clogged, obstructed, kinked or cut fuel or vacuum line Spark plug lead disconnected Faulty ignition coil Faulty kill switch Faulty regulator	Refill propane tank Open valve Remove obstruction or replace line Connect lead to spark plug Replace ignition coil Replace switch Replace regulator
Engine starts hard: Faulty choke or throttle settings Clogged, obstructed, kinked or cut fuel or vacuum line Faulty regulator Low compression	Set controls to correct position Remove obstruction or replace line Replace regulator Have engine serviced by a trained technician
Engine will not crank: Battery is discharged Loose or faulty connections or wires Faulty ignition key switch or starter control switch	Charge or replace battery Tighten, repair or replace wires Repair or replace switch(es)
Engine overheats: Incorrect fuel settings Air intake filter screen or cooling fins clogged Low oil level	Have engine serviced by a trained technician Clean and clear debris or replace filter Check and add oil
Exhaust emissions or propane odor: Carburetor or regulator setting incorrect Dirty or clogged air filter Loose fittings, clamps or hoses cracked, hoses cut or leaking	Have engine serviced by a trained technician Replace air filter Tighten or seal; check with soap and water solution, if bubbles appear, part is still leaking; replace

### ***KAWASAKI ENGINE BATTERY START WIRING DIAGRAM***

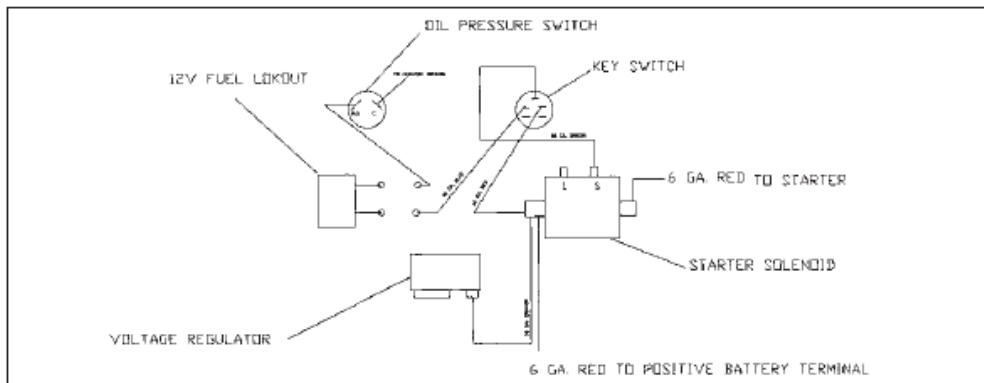

**PUREPOWERLPG™ ENGINE TUNE-UP SPECIFICATIONS**

ITEM	SPECIFICATIONS
Ignition Timing	Non-adjustable
Spark Plugs (gap)	NGK BPR4ES (.028 in)
Low Idle Speed	1500 RPM
High Idle Speed	3400 RPM
Valve Clearance	IN: 0.10-0.15 mm (0.004-0.006 in) EX: 0.10-0.15 mm (0.004-0.006 in)

**NOTICE**

High and low idle speeds may vary depending on the equipment on which the engine is used. Refer to the equipment specifications.

## TROUBLESHOOTING - ELECTRICAL SYSTEM

### **WARNING**

Always wear a face shield, safety goggles and protective clothing when working around a battery. The gases can be explosive and the acid is highly corrosive to metals, cloth and ALL HUMAN TISSUE (skin, eyes, etc.).

### **NOTICE**

Safety first. Contact an authorized service center as needed.

- Check all wire connections for obvious problems. Remove propane tank, then remove battery box cover. Check all connections visibly and physically. If any “loose”, damaged or unconnected wires are noticed, replace or repair as needed.
- Check the battery posts and wires. If the battery post(s) are corroded, remove the wires and clean posts and wires. Applying some axle grease on the posts of the battery after they are cleaned will slow down the battery corrosion process. If nothing obvious is noted, a more detailed investigation is warranted. Before any such troubleshooting begins, the following things should be done:
  - Replace propane tank with one from a machine that runs.
  - Charge the battery or provide an absolute source of 12-volt DC power capable of 50 amperes total output. Jumper cables from a car or truck battery will suffice. Use a 12-volt test light.
- If the problem appears to be in the electrical control equipment, disconnect the starter from the system so as to check the system without spinning the engine.
- Battery rundown is a common problem. An engine key left in the ON position when engine is turned OFF will result in battery running down.

## AZTEC LOWRIDER QUICK START GUIDE

<p>1.) Read, understand and observe all important <b>SAFETY INSTRUCTIONS</b> before operating the machine (see pgs 3-9).</p> <p>2.) Complete the <b>BEFORE OPERATION CHECKLIST</b> on pgs 10-11.</p> <p>3.) Make sure the machine is properly maintained prior to use (see pgs 19-24).</p> <p>4.) Make sure the LPG tank (A) is filled, connected and checked for leaks (see pg 11).</p>	<p>5.) Open the LPG tank by turning the knob (B) counter-clockwise.</p> <p>6.) Set throttle lever (C) to idle SLOW position</p> <p>7.) Turn key (D) to start [ I ] position</p> <p>8.) Move throttle lever (C) toward run FAST position. If motor fails to start, return to Step 5 above.</p> <p>9.) Set throttle lever (C) to desired operating speed and follow the moving machine (straight ahead) at moderate walking pace (keep moving).</p>
------------------------------------------------------------------------------------------------------------------------------------------------------------------------------------------------------------------------------------------------------------------------------------------------------------------------------------------------------------------------------------------	---------------------------------------------------------------------------------------------------------------------------------------------------------------------------------------------------------------------------------------------------------------------------------------------------------------------------------------------------------------------------------------------------------------------------------------------------

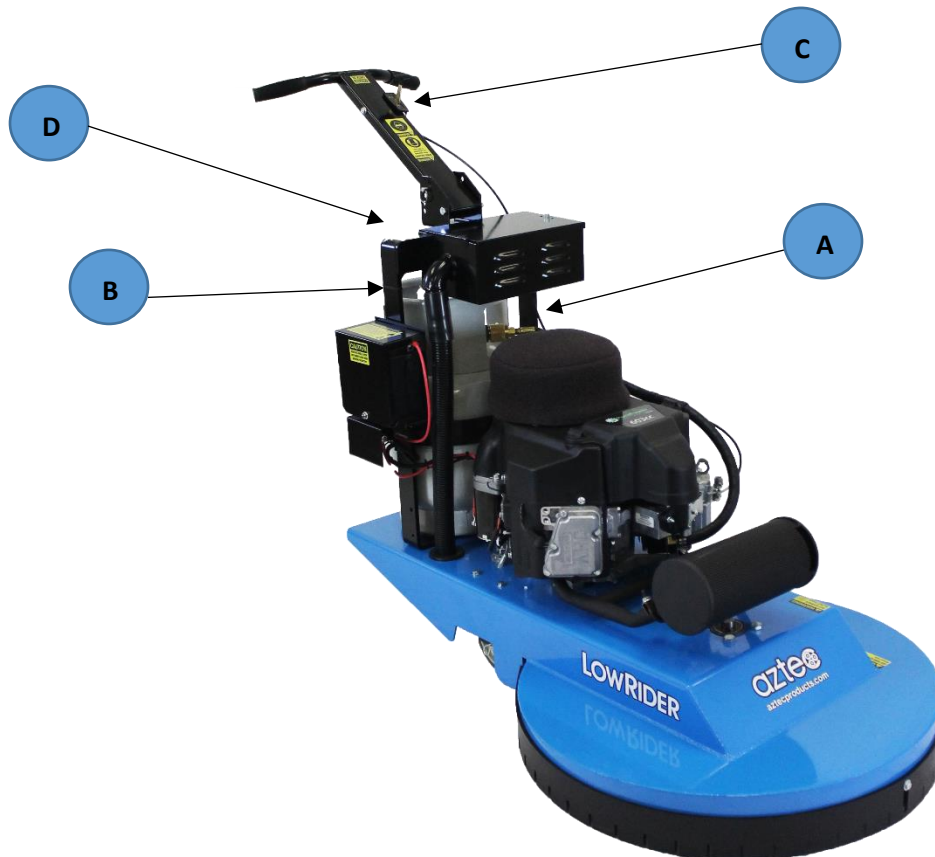

# LOWRIDER 21", 24" & 27" MODELS WARNING LABEL LOCATIONS



Order Aztec Approved replacement machine parts here: <https://aztec.parts/>

## LOWRIDER PREVENTATIVE ENGINE MAINTENANCE KIT



### The LowRider WorkSmart™ Maintenance System

The Preventative Maintenance Kit for the FS481 engine, Part # [309-603-PH](#) includes the following parts:



PART #	DESCRIPTION	QTY IN KIT
309-11013-7046	Pre Filter (Foam Hat)	1
309-11013-7049	Air Filter (Paper Element)	1
309-49065-7007	Oil Filter	1
309-92070-7004	Spark Plugs (NGK BPR4ES)	2
119-Oil-Q	10W30 Quart Oil	2
186-271964	Debris Filter (Foam Hat)	1

### LOWRIDER BODY ASSEMBLY DIAGRAM (21", 24", 27" MODELS)

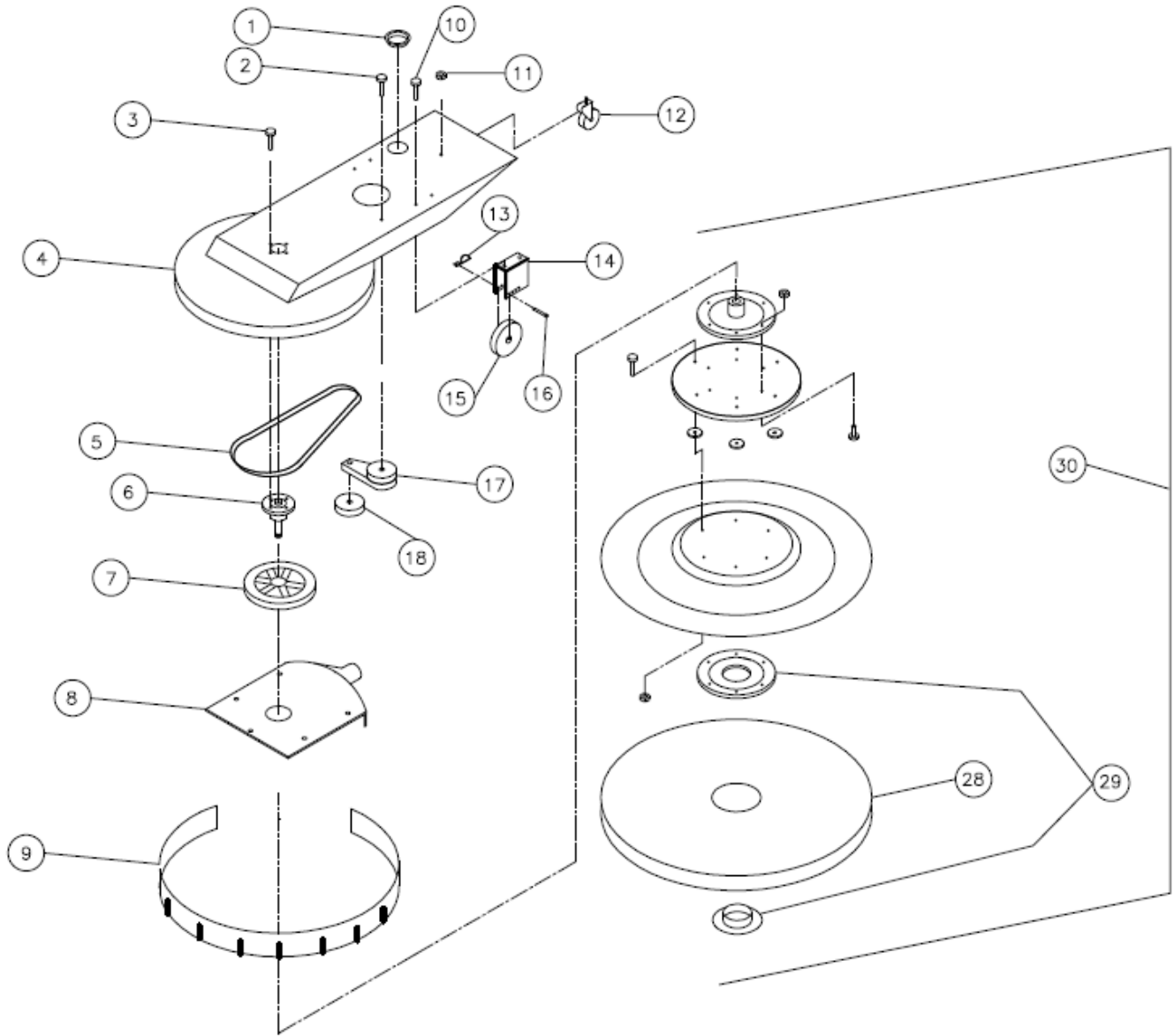

**LOWRIDER BODY ASSEMBLY PARTS (21", 24", 27" MODELS)**

REF #	DESCRIPTION	PART #	QTY
1	HOSE GROMMET	625-9280K35	1
2	3/8-16x2" BOLT	164-10123	1
3	1/2-13x1" BOLT	164-10211	4
4	BODY ASSEMBLY	21": 370-21-5 24": 370-24-5 27": 370-27-5	1
5	BELT	21": 113-BX42 24": 113-BX49 27": 113-BX51	1
6	SPINDLE ASSEMBLY	011-6-2730	1
7	PULLEY	21": 172-MB65*1 24": 011-6-2785 27": 172-MB88*1	1
8	DUST CONTROL PLATE	21": 370-21-6 24": 370-24-6 27": 370-27-6	1
9	DUST SKIRT (DOES NOT INCLUDE HARDWARE)	21": 070-21DC-SKIRT 24": 070-24DC-SKIRT 27": 070-27DC-SKIRT	1
9A	DUST SKIRT HARDWARE: 1/4-20*3/4 HCSPL 1/4- STOVER LOK NUT 5/16 FENDER WASHER ALUMINUM SPACER	164-10007 164-22831 164-20207 070-30	3 3 3 3
10	5/16-18x1" BOLT	164-10063	4
11	1/2-13 HEX NUT	164-22008	1
12	SWIVEL CASTER	011-6-2755	1
13	WHEEL BOLT	164-10131	2
14	WHEEL BRACKET	370-156-U	2
15	HEAVY DUTY 6" WHEEL W/BUSHING **	156-6-213P-H	2
16	WHEEL LOCK NUT WHEEL WASHER	164-22834 164-20155	2 4
17	BELT TENSIONER WITH 4" PULLEY	011-6-2795	1
18	4" TENSIONER PULLEY	011-6-2795A	1
28	AQUA PADS (5 PADS / CASE)	21": 250-PT21-A 24": 250-PT24-A 27": 250-PT27-A	1
29	BIG MOUTH PAD GRAB BLUE	201-792455	1
30	PAD DRIVER ASSEMBLY*	21": 070-21-PD 24": 070-24-PD 27": 070-27-PD	1

\* Burnishing pad NOT included when ordering Pad Drive Assembly (item 30 in diagram).

\* Other pad s available, contact Aztec ([parts@aztecproducts.com](mailto:parts@aztecproducts.com)) for special orders (may include lead time).

\*\* If your LowRider serial # ends in 0002672 or LOWER, you need a different wheel, part # 156-6-213P. These wheels and brackets are NOT interchangeable; contact Aztec ([parts@aztecproducts.com](mailto:parts@aztecproducts.com)) for more information.

## LOWRIDER HANDLE ASSEMBLY DIAGRAM & PARTS

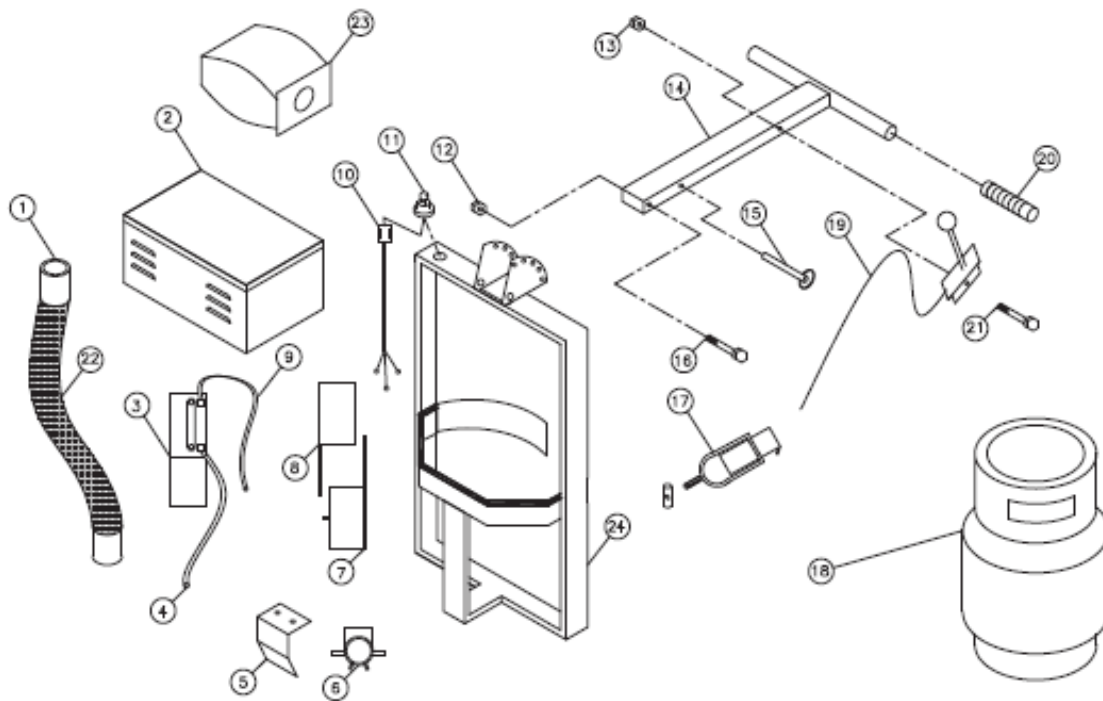

REF #	DESCRIPTION	PART #	QTY
1	HOSE CUFF	S2-47-CUFF	2
2	DUST BAG BOX ASSEMBLY EXTRA DUST BAG	370-27-10 070-DC-BAG	1 1
3	12V BATTERY	276-GTX14	1
4	SOLENOID TO STARTER CABLE	153-6-16.5	2
5	SOLENOID COVER	370-11-SC	1
6	STARTER SOLENOID	296-SS581	1
7	BATTERY BOX BOTTOM	370-11-2127B	1
8	BATTERY BOX TOP	370-11-2127T	1
9	BATTERY LEAD – BATTERY TO CONNECTOR BATTERY LEAD – CONNECTOR TO SOLENOID	153-BC-1 153-BC-2	1 1
10	WIRE HARNESS	011-762WHK	1
11	KEY SWITCH (INCLUDES KEY) EXTRA IGNITION KEY	312-308-0385 196-3112932	1 1
12	3/8-16 LOK NUT	164-22834	1
13	1/4-20 FLANGE NUT	164-14FN	1
14	T-HANDLE	370-27-25	1
15	RELEASE PIN	625-98404A395	1
16	3/8-16x3 3/4 BOLT	164-37C375HCS5Z	1
17	TOGGLE + NUT	284-TB2-60	1
18	20# LPG PROPANE CYLINDER WITH OPD	293-20#STLMF	1
19	THROTTLE CABLE	212-1	1
20	HANDLE GRIPS	224-987319	2
21	1/2-20x3 3/4 BOLT	164-25C375HCS5Z	1
22	DUST HOSE (SOLD BY THE FOOT)	S2-47	3 FT
23	DUST BAG	070-DC-BAG	1
24	HANDLE ASSEMBLY	370-27-20	1

## FUEL SYSTEM DIAGRAM & PARTS

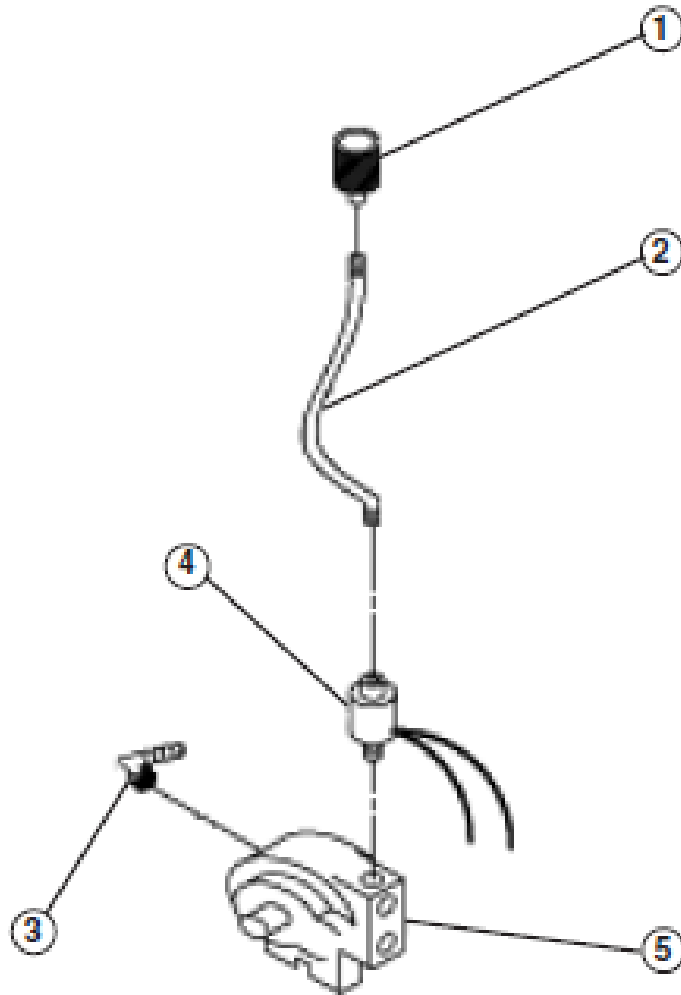

REF #	DESCRIPTION	PART #	QTY
1	QUICK COUPLER	152-700	1
2	LPG HOSE 18"	267-P5561-0410	1
3	FUEL HOSE FITTING	166-62040-B	1
4	FUEL LOK-OUT (12 VOLT)	152-N3-0173-1	1
5	FUEL REGULATOR (T60-E)	152-500	1

# AZTEC PUREPOWERLPG 603cc FS481V ENGINE DIAGRAM

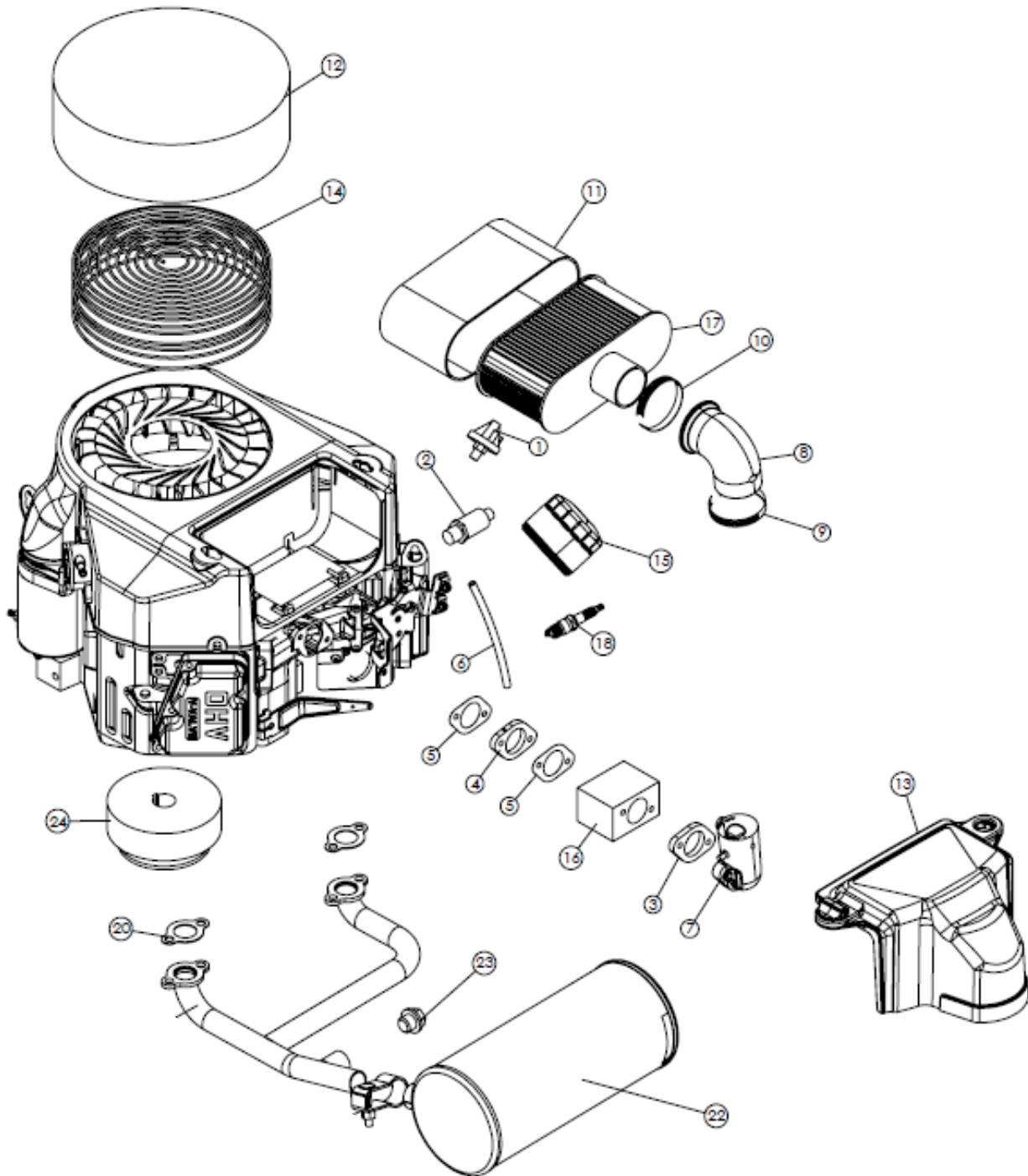

## AZTEC PUREPOWERLPG 603cc FS481V ENGINE PARTS

REF	DESCRIPTION	PART #	QTY
1	OIL PRESSURE SWITCH 17HP	152-N3-0082	1
2	VALVE OIL DRAIN 14HP/17HP	312-504-0185	1
3	GASKET AIR FILTER FS481	309-11061-7095	1
4	INSULATOR CARB SPACER FS481	309-16073-7007	1
5	INSULATOR CARB GASKET FS481	309-11061-7096	2
6	VENT TUBE AIR CLEANER FS481	309-92192-7146	1
7	PIPE INTAKE FS481	309-16060-7036	1
8	TUBE ELBOW AIR CLEANER FS481	309-92192-7164	1
9	PIPE INTAKE CLAMP FS481	309-92171-7010	1
10	HOSE CLAMP FS481	309-92173-7007	1
11	PRE FILTER CLEANER FS481	309-11013-7046	1
12	FOAM HAT FILTER KW	186-271964	1
13	AIR FILTER COVER FS481	309-11011-7060	1
	Air Filter Cover Wing Nut	309-92210-7038	2
	Air Filter Cover O-Ring	309-92055-7025	2
14	DEBRIS SCREEN FS481	309-18540-603	1
15	FILTER-OIL FS481	309-49065-7007	1
16	CARB (DOES NOT INCLUDE THROTTLE PLATE, SHAFT OR SEAL)	152-CARB	1
17	ELEMENT AIR FILTER FS481	309-11013-7049	1
18	SPARK PLUG BPR4ES	309-92070-7004	2
20	EXHAUST GASKET, MANIFOLD FS481	309-11060-7016	2
22	1 PIECE CATALYTIC MUFFLER MANIFOLD	152-603-BC	1
23	MANIFOLD PLUG	164-M1815P	1
24	CENTRIFUGAL CLUTCH	311-180007	1

## AZTEC LOWRIDER WARRANTY

You have purchased a quality machine. Each of its components have been tested and approved for use by Aztec Products, Inc. It is unlikely that you will ever have a warranty claim if you properly maintain your machine.

The need for proper maintenance and care for this machine cannot be overstated. Poor maintenance, neglect or abuse will void the warranty and prove to be very expensive.

This warranty is limited as follows:

<b>Component</b>	<b>Term of Warranty</b>
Engine	2 yrs from engine manufacturer
Machine	1 yr from machine manufacturer
Fuel System	1 yr
LPG Tank	1 yr on valve, 3 yrs on cylinder from date of manufacture
Body Parts	1 yr
Battery	1 yr prorated from battery manufacturer
Centrifugal Clutch	1 yr

This warranty does not apply to certain consumable or wear parts such as:

Pads, Pulleys, Springs, Belts, Engine Tune Up Parts, Etc.

Aztec Products, Inc. warrants its floor machine to be free from defects in material and workmanship for a period of one year from the date of sale. All engines are warranted by the manufacturer for a period of two years, when engine maintenance schedules are followed.

This warranty does not apply to damage or failure caused by abuse, misuse, neglect, disassembly, alteration, unauthorized modification or repair, lack of proper maintenance, theft or damage by freight carriers. Aztec is not liable for transportation to or from repair centers or travel for on-site repairs. Aztec will not be liable for incidental or consequential damages arising from the use of any of its products, whether defective or not.

Aztec agrees, at its discretion, to repair or replace at its own expense any machine or part(s) when examination proves to be defective in workmanship or materials, provided that the purchaser notifies Aztec within the warranty period and follows the Return Goods Policy. Engine repairs may be performed at an authorized engine manufacturer service center. For an authorized engine repair center, call Kawasaki, 800-433-5640, or visit <https://www.kawasaki.com/dealerlocatorpower>.

To request warranty approval, the following procedure must be followed:

1. Send an email to [parts@aztecproducts.com](mailto:parts@aztecproducts.com) and provide a detailed description of the issue; include your name, your company name, and pictures of the problem for clarification.
2. If you purchased the item through a Distributor, please contact them first. If you are not satisfied, email Aztec and provide the distributor name, purchase date, and the serial number of the product. Aztec maintains the serial number, date of shipment or sale, and customer name on each piece of equipment and replacement parts sold.
3. If your request is approved, Aztec will issue an RGA (Return Goods Authorization) number. The defective item must be returned via freight prepaid to Aztec with the RGA #, accompanied by a copy of the original invoice. Aztec is not responsible for the cost of packaging inbound freight, nor inbound freight damage. Pack item carefully and send tracking information to [parts@aztecproducts.com](mailto:parts@aztecproducts.com).
4. Only Aztec Products, Inc. or its authorized dealers may make warranty repairs on machines manufactured by Aztec. Others do so at their own risk and expense.
5. Aztec may offer to do warranty related repairs free of charge at the manufacturing facility, however approval and arrangements must be made in advance, as outlined above. Aztec will not accept freight collect returns or returns that do not indicate an RGA number.

**This warranty is non-transferable.**

**AZTEC PRODUCTS, INC • [www.aztecproducts.com](http://www.aztecproducts.com)  
201 Commerce Drive • Montgomeryville, PA 18936 • 215-393-4700**

**[parts@aztecproducts.com](mailto:parts@aztecproducts.com)**